

## USB-Friendly Lithium-Ion Battery Charger and Power-Path Management IC

Check for Samples: [bq24230H](#), [bq24232H](#)

### FEATURES

- **Fully Compliant USB Charger**
  - **Selectable 100-mA and 500-mA Maximum Input Current**
  - **100-mA Maximum Current Limit Ensures Compliance to USB-IF Standard**
  - **Input-based Dynamic Power Management ( $V_{IN}$ -DPM) for Protection Against Poor USB Sources**
- **28-V Input Rating With Overvoltage Protection**
- **4.35-V Battery Regulation**
- **Integrated Dynamic Power-Path Management (DPPM) Function Simultaneously and Independently Powers the System and Charges the Battery**
- **Supports up to 500-mA Charge Current With Current Monitoring Output (ISET)**
- **Programmable Input Current Limit up to 500 mA for Wall Adapters**
- **Programmable Termination Current (bq24232H)**
- **Programmable Precharge and Fast-Charge Safety Timers**
- **Reverse Current, Short-Circuit, and Thermal Protection**
- **NTC Thermistor Input**
- **Proprietary Start-Up Sequence Limits Inrush Current**
- **Status Indication – Charging/Done, Power Good**
- **Small 3 mm × 3 mm 16-Lead QFN Package**

### APPLICATIONS

- **Bluetooth™ Devices**
- **Low-Power Handheld Devices**

### DESCRIPTION

The bq2423xH series of devices are highly integrated Li-ion linear chargers and system power-path management devices targeted at space-limited portable applications. The devices operate from either a USB port or ac adapter and support charge currents between 25 mA and 500 mA. The high-input-voltage range with input overvoltage protection supports low-cost, unregulated adapters. The USB input current limit accuracy and start-up sequence allow the bq2423xH to meet USB-IF inrush current specification. Additionally, the input dynamic power management ( $V_{IN}$ -DPM) prevents the charger from crashing poorly designed or incorrectly configured USB sources.

The bq2423xH features dynamic power-path management (DPPM) that powers the system while simultaneously and independently charging the battery. The DPPM circuit reduces the charge current when the input current limit causes the system output to fall to the DPPM threshold, thus supplying the system load at all times while monitoring the charge current separately. This feature reduces the number of charge and discharge cycles on the battery, allows for proper charge termination, and enables the system to run with a defective or absent battery pack. Additionally, this enables instant system turn-on even with a totally discharged battery. The power-path management architecture also permits the battery to supplement the system current requirements when the adapter cannot deliver the peak system currents, enabling the use of a smaller adapter.

### TYPICAL APPLICATION CIRCUIT

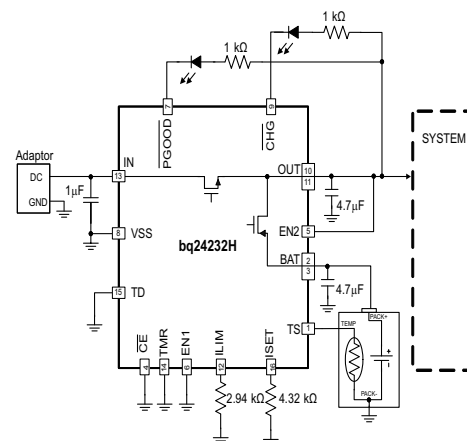

Please be aware that an important notice concerning availability, standard warranty, and use in critical applications of Texas Instruments semiconductor products and disclaimers thereto appears at the end of this data sheet.

Bluetooth is a trademark of Bluetooth SIG, Inc..



These devices have limited built-in ESD protection. The leads should be shorted together or the device placed in conductive foam during storage or handling to prevent electrostatic damage to the MOS gates.

## DESCRIPTION (CONTINUED)

The battery is charged in three phases: conditioning, constant current, and constant voltage. In all charge phases, an internal control loop monitors the IC junction temperature and reduces the charge current if the internal temperature threshold is exceeded.

The charger power stage and charge current sense functions are fully integrated. The charger function has high-accuracy current and voltage regulation loops, charge status display, and charge termination. The input current limit and charge current are programmable using external resistors.

## TERMINAL CONFIGURATION AND FUNCTIONS

RGT PACKAGE  
(Top View)

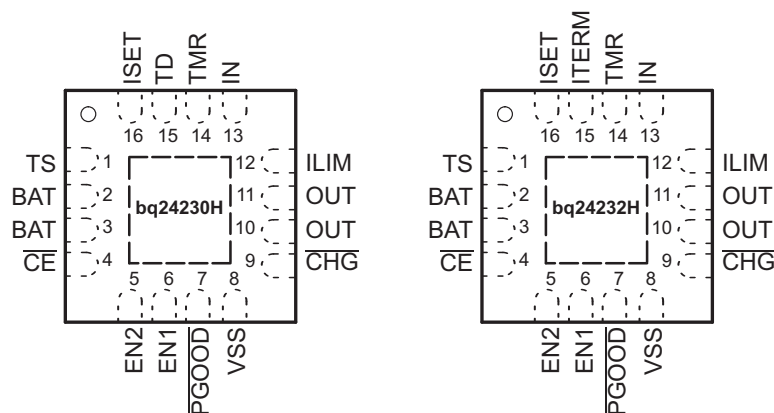

## Terminal Functions

Terminal NAME	Terminal NUMBER		I/O	DESCRIPTION
	'230H	'232H		
TS	1	1	I	External NTC Thermistor Input. Connect the TS input to the NTC thermistor in the battery pack. TS monitors a 10-k $\Omega$ NTC thermistor. For applications that do not utilize the TS function, connect a 10-k $\Omega$ fixed resistor from TS to VSS to maintain a valid voltage level on TS.
BAT	2,3	2, 3	I/O	Charger Power Stage Output and Battery Voltage Sense Input. Connect BAT to the positive terminal of the battery. Bypass BAT to VSS with a 4.7- $\mu$ F to 47- $\mu$ F ceramic capacitor.
$\overline{CE}$	4	4	I	Charge Enable Active-Low Input. Connect $\overline{CE}$ to a high logic level to place the battery charger in standby mode. In standby mode, OUT is active and battery supplement mode is still available. Connect $\overline{CE}$ to a low logic level to enable the battery charger. $\overline{CE}$ is internally pulled down with ~285 k $\Omega$ . Do not leave $\overline{CE}$ unconnected to ensure proper operation.
EN2	5	5	I	Input Current Limit Configuration Inputs. Use EN1 and EN2 control the maximum input current and enable USB compliance. See Table 2 for the description of the operation states. EN1 and EN2 are internally pulled down with ~285 k $\Omega$ . Do not leave EN1 or EN2 unconnected to ensure proper operation.
EN1	6	6	I	
$\overline{PGOOD}$	7	7	O	Open-drain Power Good Status Indication Output. $\overline{PGOOD}$ pulls to VSS when a valid input source is detected. $\overline{PGOOD}$ is high-impedance when the input power is not within specified limits. Connect $\overline{PGOOD}$ to the desired logic voltage rail using a 1-k $\Omega$ – 100-k $\Omega$ resistor, or use with an LED for visual indication.
VSS	8	8	–	Ground. Connect to the thermal pad and to the ground rail of the circuit.
$\overline{CHG}$	9	9	O	Open-Drain Charging Status Indication Output. $\overline{CHG}$ pulls to VSS when the battery is charging. $\overline{CHG}$ is high impedance when charging is complete and when charger is disabled.
OUT	10,11	10, 11	O	System Supply Output. OUT provides a regulated output when the input is below the OVP threshold and above the regulation voltage. When the input is out of the operation range, OUT is connected to $V_{BAT}$ . Connect OUT to the system load. Bypass OUT to VSS with a 4.7- $\mu$ F to 47- $\mu$ F ceramic capacitor.
ILIM	12	12	I	Adjustable Current Limit Programming Input. Connect a 3.1-k $\Omega$ to 7.8-k $\Omega$ resistor from ILIM to VSS to program the maximum input current (EN2=1, EN1=0). The input current includes the system load and the battery charge current.
IN	13	13	I	Input Power Connection. Connect IN to the connected to external DC supply (AC adapter or USB port). The input operating range is 4.35 V to 6.6 V. The input can accept voltages up to 26 V without damage but operation is suspended. Connect bypass capacitor 1 $\mu$ F to 10 $\mu$ F to VSS.

**Terminal Functions (continued)**

Terminal			I/O	DESCRIPTION
NAME	NUMBER			
	'230H	'232H		
TMR	14	14	I	Timer Programming Input. TMR controls the precharge and fast-charge safety timers. Connect TMR to VSS to disable all safety timers. Connect a 18-kΩ to 72-kΩ resistor between TMR and VSS to program the timers a desired length. Leave TMR unconnected to set the timers to the 5-hour fast charge and 30-minute precharge default timer values.
TD	15	-	I	Termination Dsable Input. Connect TD high to disable charger termination. Connect TD to VSS to enable charger termination. TD is checked during start-up only and cannot be changed during operation. See the TD section in this data sheet for a description of the behavior when termination is disabled. TD is internally pulled down to VSS with ~285 kΩ. Do not leave TD unconnected to ensure proper operation.
ITERM	-	15	I	Termination Current Programming Input. Connect a 0-Ω to 15-kΩ resistor from ITERM to VSS to program the termination current. Leave ITERM unconnected to set the termination current to the internal default 10% threshold.
ISET	16	16	I/O	Fast-Charge Current Programming Input. Connect a 3-kΩ to 36-kΩ resistor from ISET to VSS to program the fast-charge current level. Charging is disabled if ISET is left unconnected. While charging, the voltage at ISET reflects the actual charging current and can be used to monitor charge current. See the <a href="#">CHARGE CURRENT TRANSLATOR</a> section for more details.
Thermal Pad			-	An internal electrical connection exists between the exposed thermal pad and the VSS pin of the device. The thermal pad must be connected to the same potential as the VSS pin on the printed-circuit board. Do not use the thermal pad as the primary ground input for the device. The VSS pin must be connected to ground at all times.

**Table 1. EN1/EN2 Settings**

EN2	EN1	Maximum input current into IN pin
0	0	100 mA. USB100 mode
0	1	500 mA. USB500 mode
1	0	Set by an external resistor from ILIM to VSS
1	1	Standby (USB suspend mode)

**ORDERING INFORMATION**

PART NUMBER <sup>(1) (2)</sup>	V <sub>OVP</sub>	V <sub>OUT(REG)</sub>	V <sub>DPM</sub>	OPTIONAL FUNCTION	MARKING
bq24230HRGTR <sup>(3)</sup>	6.6 V	4.5 V	V <sub>O(REG)</sub> – 100 mV	TD	24230H
bq24230HRGTT <sup>(3)</sup>	6.6 V	4.5 V	V <sub>O(REG)</sub> – 100 mV	TD	24230H
bq24232HRGTR	10.5 V	4.5 V	V <sub>O(REG)</sub> – 100 mV	ITERM	24232H
bq24232HRGTT	10.5 V	4.5 V	V <sub>O(REG)</sub> – 100 mV	ITERM	24232H

- (1) The RGT package is available in the following options:  
R - taped and reeled in quantities of 3000 devices per reel.  
T - taped and reeled in quantities of 250 devices per reel.
- (2) This product is RoHS compatible, including a lead concentration that does not exceed 0.1% of total product weight, and is suitable for use in specified lead-free soldering processes. In addition, this product uses package materials that do not contain halogens, including bromine (Br) or antimony (Sb) above 0.1% of total product weight.
- (3) Product Preview

## ABSOLUTE MAXIMUM RATINGS<sup>(1)</sup>

over the 0°C to 125°C operating free-air temperature range (unless otherwise noted)

			MIN	MAX	UNIT
V <sub>I</sub>	Input voltage	IN (with respect to VSS)	-0.3	28	V
		OUT (with respect to VSS)	-0.3	7	V
		BAT (with respect to VSS)	-0.3	5	V
		EN1, EN2, $\overline{CE}$ , TS, ISET, $\overline{PGOOD}$ , $\overline{CHG}$ , ILIM, TMR, TD, ITERM (with respect to VSS)	-0.3	7	V
I <sub>I</sub>	Input current	IN		600	mA
I <sub>O</sub>	Output current (continuous)	OUT		1700	mA
		BAT (Discharge mode)		1700	mA
	Output sink current	$\overline{CHG}$ , $\overline{PGOOD}$		15	mA
T <sub>J</sub>	Junction temperature		-40	150	°C
T <sub>stg</sub>	Storage temperature		-65	150	°C

- (1) Stresses beyond those listed under absolute maximum ratings may cause permanent damage to the device. These are stress ratings only, and functional operation of the device at these or any other conditions beyond those indicated under recommended operating conditions is not implied. Exposure to absolute-maximum-rated conditions for extended periods may affect device reliability. All voltage values are with respect to the network ground terminal unless otherwise noted.

## RECOMMENDED OPERATING CONDITIONS

			MIN	MAX	UNIT	
V <sub>I</sub>	IN voltage range		4.35	26	V	
		IN operating voltage range	'230H	4.35	6.4	V
			'232H	4.35	10.2	V
I <sub>IN</sub>	Input current, IN pin			500	mA	
I <sub>OUT</sub>	Current, OUT pin			1500	mA	
I <sub>BAT</sub>	Current, BAT pin (discharging)			1500	mA	
I <sub>CHG</sub>	Current, BAT pin (charging)			500	mA	
T <sub>J</sub>	Junction temperature		-40	125	°C	
R <sub>ILIM</sub>	Maximum input current programming resistor		3.1	7.8	kΩ	
R <sub>ISET</sub>	Fast-charge current programming resistor		1.74	34.8	kΩ	
R <sub>TMR</sub>	Timer programming resistor		18	72	kΩ	
R <sub>ITERM</sub>	Termination programming resistor	'232H	0	15	kΩ	

## THERMAL INFORMATION

THERMAL METRIC <sup>(1)</sup>		RGT	UNITS
		16 PINS	
θ <sub>JA</sub>	Junction-to-ambient thermal resistance	44.5	°C/W
θ <sub>JCtop</sub>	Junction-to-case (top) thermal resistance	54.2	
θ <sub>JB</sub>	Junction-to-board thermal resistance	17.2	
ψ <sub>JT</sub>	Junction-to-top characterization parameter	1.0	
ψ <sub>JB</sub>	Junction-to-board characterization parameter	17.1	
θ <sub>JCbot</sub>	Junction-to-case (bottom) thermal resistance	3.8	

- (1) For more information about traditional and new thermal metrics, see the IC Package Thermal Metrics application report, [SPRA953](#).

## ELECTRICAL CHARACTERISTICS

over operating free-air temperature range (unless otherwise noted)

PARAMETER		TEST CONDITIONS	MIN	TYP	MAX	UNIT
<b>INPUT</b>						
UVLO	Undervoltage lockout	$V_{IN}: 0\text{ V} \rightarrow 4\text{ V}$	3.2	3.3	3.4	V
$V_{hys(UVLO)}$	Hysteresis on UVLO	$V_{IN}: 4\text{ V} \rightarrow 0\text{ V}$	200		300	mV
$V_{IN(DT)}$	Input power detection threshold	Input power detected when $V_{IN} > V_{BAT} + V_{IN(DT)}$ $V_{BAT} = 3.6\text{ V}$ , $V_{IN}: 3.5\text{ V} \rightarrow 4\text{ V}$	55	95	145	mV
$V_{hys(INDT)}$	Hysteresis on $V_{IN(DT)}$	$V_{BAT} = 3.6\text{ V}$ , $V_{IN}: 4\text{ V} \rightarrow 3.5\text{ V}$	20			mV
$t_{DGL(PGOOD)}$	Deglitch time, input power detected status	Time measured from $V_{IN}: 0\text{ V} \rightarrow 5\text{ V}$ 1- $\mu\text{s}$ rise time to $\overline{PGOOD} = \text{LO}$		2		ms
$V_{OVP}$	Input overvoltage protection threshold	(230H) $V_{IN}: 5\text{ V} \rightarrow 7\text{ V}$ (232H) $V_{IN}: 5\text{ V} \rightarrow 11\text{ V}$	6.4 10.2	6.6 10.5	6.8 10.8	V
$V_{hys(OVP)}$	Hysteresis on OVP	(230H) $V_{IN}: 7\text{ V} \rightarrow 5\text{ V}$ (232H) $V_{IN}: 11\text{ V} \rightarrow 5\text{ V}$		110 175		mV
$t_{DGL(OVP)}$	Input overvoltage blanking time			50		$\mu\text{s}$
$t_{REC(OVP)}$	Input overvoltage recovery time	Time measured from $V_{IN}: 11\text{ V} \rightarrow 5\text{ V}$ 1 $\mu\text{s}$ fall time to $\overline{PGOOD} = \text{LO}$		2		ms
<b>ILIM, ISET SHORT CIRCUIT TEST</b>						
$I_{SC}$	Current source	$V_{IN} > \text{UVLO}$ and $V_{IN} > V_{BAT} + V_{IN(DT)}$		1.3		mA
$V_{SC}$		$V_{IN} > \text{UVLO}$ and $V_{IN} > V_{BAT} + V_{IN(DT)}$		520		mV
<b>QUIESCENT CURRENT</b>						
$I_{BAT(PDWN)}$	Sleep current into BAT pin	$\overline{CE} = \text{LO}$ or HI, input power not detected, no load on OUT pin, $T_J = 85^\circ\text{C}$			6.5	$\mu\text{A}$
$I_{IN(STDBY)}$	Standby current into IN pin	EN1 = HI, EN2 = HI, $V_{IN} = 6\text{ V}$ , $T_J = 85^\circ\text{C}$ EN1 = HI, EN2 = HI, $V_{IN} = 10\text{ V}$ , $T_J = 85^\circ\text{C}$			50 200	$\mu\text{A}$
$I_{CC}$	Active supply current, IN pin	$\overline{CE} = \text{LO}$ , $V_{IN} = 6\text{ V}$ , no load on OUT pin, $V_{BAT} > V_{BAT(REG)}$ , (EN1, EN2) $\neq$ (HI, HI)			1.5	mA
<b>POWER PATH</b>						
$V_{DO(IN-OUT)}$	$V_{IN} - V_{OUT}$	$V_{IN} = 4.45\text{ V}$ , $I_{IN} = 500\text{ mA}$ , $V_{BAT} = 4.35\text{ V}$		150	237.5	mV
$V_{DO(BAT-OUT)}$	$V_{BAT} - V_{OUT}$	$I_{OUT} = 500\text{ mA}$ , $V_{IN} = 0\text{ V}$ , $V_{BAT} > 3\text{ V}$			62.5	mV
$V_{O(REG)}$	OUT pin voltage regulation	$V_{IN} > V_{OUT} + V_{DO(IN-OUT)}$	4.4	4.5	4.6	V
$I_{INmax}$	Maximum input current	EN1 = LO, EN2 = LO EN1 = HI, EN2 = LO EN1 = LO, EN2 = HI	90 450	95 475	100 500	mA A
$K_{ILIM}$	Maximum input current factor	$I_{LIM} = 200\text{ mA}$ to $500\text{ mA}$	1380	1530	1680	A $\Omega$
$I_{INmax}$	Programmable input current limit range	EN2 = HI, EN1 = LO, $R_{ILIM} = 3.1\text{ k}\Omega$ to $7.8\text{ k}\Omega$	200		500	mA
$V_{IN-DPM}$	Input voltage threshold when input current is reduced	EN2 = LO, EN1 = X	4.35	4.50	4.63	V
$V_{DPPM}$	Output voltage threshold when charging current is reduced		$V_{O(REG)} - 180\text{ mV}$	$V_{O(REG)} - 100\text{ mV}$	$V_{O(REG)} - 30\text{ mV}$	V
$V_{BSUP1}$	Enter battery supplement mode	$V_{BAT} = 3.6\text{ V}$ , $R_{ILIM} = 1.5\text{ k}\Omega$ , $R_{LOAD} = 10\ \Omega \rightarrow 2\ \Omega$		$V_{OUT} \leq V_{BAT} - 40\text{ mV}$		V
$V_{BSUP2}$	Exit battery supplement mode	$V_{BAT} = 3.6\text{ V}$ , $R_{ILIM} = 1.5\text{ k}\Omega$ , $R_{LOAD} = 2\ \Omega \rightarrow 10\ \Omega$		$V_{OUT} \geq V_{BAT} - 20\text{ mV}$		V
$V_{O(SC1)}$	Output short-circuit detection threshold, power-on	$V_{IN} > \text{UVLO}$ and $V_{IN} > V_{BAT} + V_{IN(DT)}$	0.8	0.9	1	V
$V_{O(SC2)}$	Output short-circuit detection threshold, supplement mode $V_{BAT} - V_{OUT} > V_{O(SC2)}$ indicates short circuit	$V_{IN} > \text{UVLO}$ and $V_{IN} > V_{BAT} + V_{IN(DT)}$	200	250	300	mV
$t_{DGL(SC2)}$	Deglitch time, supplement mode short circuit			250		$\mu\text{s}$
$t_{REC(SC2)}$	Recovery time, supplement mode short circuit			60		ms

## ELECTRICAL CHARACTERISTICS (continued)

over operating free-air temperature range (unless otherwise noted)

PARAMETER		TEST CONDITIONS	MIN	TYP	MAX	UNIT
<b>BATTERY CHARGER</b>						
$I_{BAT(SC)}$	Source current for BAT pin short-circuit detection	$V_{BAT} = 1.5\text{ V}$	4	7.5	11	mA
$V_{BAT(SC)}$	BAT pin short-circuit detection threshold	$V_{BAT}$ rising	1.6	1.8	2	V
$V_{BAT(REG)}$	Battery charge voltage		4.306	4.35	4.394	V
$V_{LOWV}$	Precharge to fast-charge transition threshold	$V_{IN} > UVLO$ and $V_{IN} > V_{BAT} + V_{IN(DT)}$	2.9	3	3.1	V
$t_{DGL1(LOWV)}$	Deglitch time on precharge to fast-charge transition			25		ms
$t_{DGL2(LOWV)}$	Deglitch time on fast-charge to precharge transition			25		ms
$I_{CHG}$	Battery fast-charge current range	$V_{BAT(REG)} > V_{BAT} > V_{LOWV}$ , $V_{IN} = 5\text{ V}$ , $\overline{CE} = LO$ , $EN1 = LO$ , $EN2 = HI$	25		500	mA
	Battery fast-charge current	$\overline{CE} = LO$ , $EN1 = LO$ , $EN2 = HI$ , $V_{BAT} > V_{LOWV}$ , $V_{IN} = 5\text{ V}$ , $I_{INmax} > I_{CHG}$ , no load on OUT pin, thermal loop and DPM loop not active		$K_{ISET}/R_{ISET}$		A
$K_{ISET}$	Fast-charge current factor	$25\text{ mA} \leq I_{CHG} \leq 500\text{ mA}$	797	870	975	AΩ
$K_{PRECHG}$	Precharge current factor	$2.5\text{ mA} \leq I_{PRECHG} \leq 50\text{ mA}$	70	88	106	AΩ
$I_{TERM}$	Termination comparator threshold for internally set termination detection	$\overline{CE} = LO$ , $(EN1, EN2) \neq (LO, LO)$ , $V_{BAT} > V_{RCH}$ , $t < t_{MAXCH}$ , $V_{IN} = 5\text{ V}$ , DPM loop and thermal loop not active	$0.09 \times I_{CHG}$	$0.1 \times I_{CHG}$	$0.11 \times I_{CHG}$	A
		$\overline{CE} = LO$ , $(EN1, EN2) = (LO, LO)$ , $V_{BAT} > V_{RCH}$ , $t < t_{MAXCH}$ , $V_{IN} = 5\text{ V}$ , DPM loop and thermal loop not active	$0.027 \times I_{CHG}$	$0.033 \times I_{CHG}$	$0.040 \times I_{CHG}$	
$I_{TERM}$	Termination current threshold for programmable termination detection	$I_{TERM} = 0\%$ to $50\%$ of $I_{CHG}$	$K_{ITER} \times R_{ITER}/R_{ISET}$			A
$I_{BIAS(ITERM)}$	Current for external termination-setting resistor		72	75	78	μA
$K_{ITERM}$	K factor for termination detection threshold (externally set) (bq24232H)	$\overline{CE} = LO$ , $(EN1, EN2) \neq (LO, LO)$ , $V_{BAT} > V_{RCH}$ , $t < t_{MAXCH}$ , $V_{IN} = 5\text{ V}$ , DPM loop and thermal loop not active	0.024	0.030	0.036	A
		$\overline{CE} = LO$ , $(EN1, EN2) = (LO, LO)$ , $V_{BAT} > V_{RCH}$ , $t < t_{MAXCH}$ , $V_{IN} = 5\text{ V}$ , DPM loop and thermal loop not active	0.009	0.010	0.011	
$t_{DGL(TERM)}$	Deglitch time, termination detected			25		ms
$V_{RCH}$	Recharge detection threshold	$V_{IN} > UVLO$ and $V_{IN} > V_{BAT} + V_{IN(DT)}$	$V_{BAT(REG)} - 140\text{ mV}$	$V_{BAT(REG)} - 100\text{ mV}$	$V_{BAT(REG)} - 60\text{ mV}$	V
$t_{DGL(RCH)}$	Deglitch time, recharge threshold detected			62.5		ms
$t_{DGL(NO-IN)}$	Delay time, input power loss to charger turnoff	$V_{BAT} = 3.6\text{ V}$ . Time measured from $V_{IN}: 5\text{ V} \rightarrow 3\text{ V}$ 1-μs fall time		20		ms
$I_{BAT(DET)}$	Sink current for battery detection	$V_{BAT} = 2.5\text{ V}$	5	7.5	10	mA
$t_{DET}$	Battery detection timer	BAT high or low		250		ms
<b>BATTERY CHARGING TIMERS</b>						
$t_{PRECHG}$	Precharge safety timer value	TMR = floating	1440	1800	2160	s
$t_{MAXCHG}$	Charge safety timer value	TMR = floating	14400	18000	21600	s
$t_{PRECHG}$	Precharge safety timer value	$18\text{ k}\Omega < R_{TMR} < 72\text{ k}\Omega$	$R_{TMR} \times K_{TMR}$			s
$t_{MAXCHG}$	Charge safety timer value	$18\text{ k}\Omega < R_{TMR} < 72\text{ k}\Omega$	$10 \times R_{TMR} \times K_{TMR}$			s
$K_{TMR}$	Timer factor		30	40	50	s/kΩ

## ELECTRICAL CHARACTERISTICS (continued)

over operating free-air temperature range (unless otherwise noted)

PARAMETER		TEST CONDITIONS	MIN	TYP	MAX	UNIT
<b>BATTERY-PACK NTC MONITOR <sup>(1)</sup></b>						
$I_{NTC}$	NTC bias current	$V_{IN} > UVLO$ and $V_{IN} > V_{BAT} + V_{IN(DT)}$	72	75	78	$\mu A$
$V_{HOT}$	High-temperature trip point	Battery charging, $V_{TS}$ Falling	270	300	330	mV
$V_{HYS(HOT)}$	Hysteresis on high trip point	Battery charging, $V_{TS}$ Rising from $V_{HOT}$		30		mV
$V_{COLD}$	Low-temperature trip point	Battery charging, $V_{TS}$ Rising	2000	2100	2200	mV
$V_{HYS(COLD)}$	Hysteresis on low trip point	Battery charging, $V_{TS}$ Falling from $V_{COLD}$		300		mV
$t_{DGL(TS)}$	Deglintch time, pack temperature fault detection	Battery charging, $V_{TS}$ Falling		50		ms
$V_{DIS(TS)}$	TS function disable threshold	TS unconnected (applies with TD pin on bq24230H)		$V_{IN}-200$ mV		V
<b>THERMAL REGULATION</b>						
$T_{J(REG)}$	Temperature regulation limit			125		$^{\circ}C$
$T_{J(OFF)}$	Thermal shutdown temperature	$T_J$ rising		155		$^{\circ}C$
$T_{J(OFF-HYS)}$	Thermal shutdown hysteresis			20		$^{\circ}C$
<b>LOGIC LEVELS ON EN1, EN2, <math>\overline{CE}</math>, TD</b>						
$V_{IL}$	Logic LOW input voltage		0		0.4	V
$V_{IH}$	Logic HIGH input voltage		1.4		6.0	V
$I_{IL}$	Input sink current	$V_{IL} = 0$ V			1	$\mu A$
$I_{IH}$	Input source current	$V_{IH} = 1.4$ V			10	$\mu A$
<b>LOGIC LEVELS ON <math>\overline{PGOOD}</math>, <math>\overline{CHG}</math></b>						
$V_{OL}$	Output LOW voltage	$I_{SINK} = 5$ mA			0.4	V

- (1) These numbers set trip points of 0 $^{\circ}C$  and 50 $^{\circ}C$  while charging, with 3 $^{\circ}C$  hysteresis on the trip points, with a Vishay Type 2 curve NTC with an R25 of 10 k $\Omega$ .

## TYPICAL CHARACTERISTICS

Typical Application Circuit, EN1 = 0, EN2 = 1,  $T_A = 25^\circ\text{C}$ , unless otherwise noted.

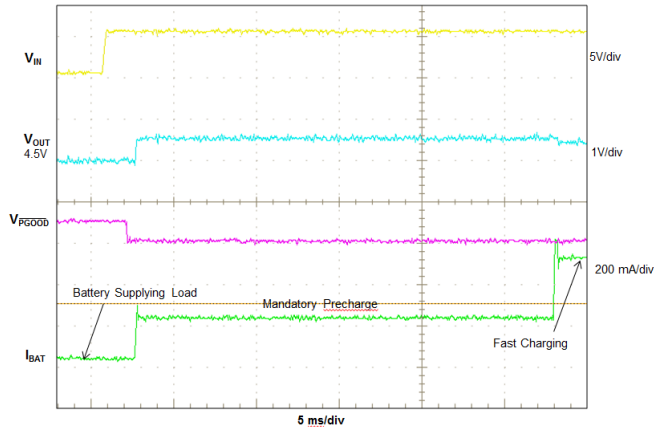

Figure 1. ADAPTER PLUG-IN WITH BATTERY CONNECTED  
 $R_{LOAD} = 25\Omega$

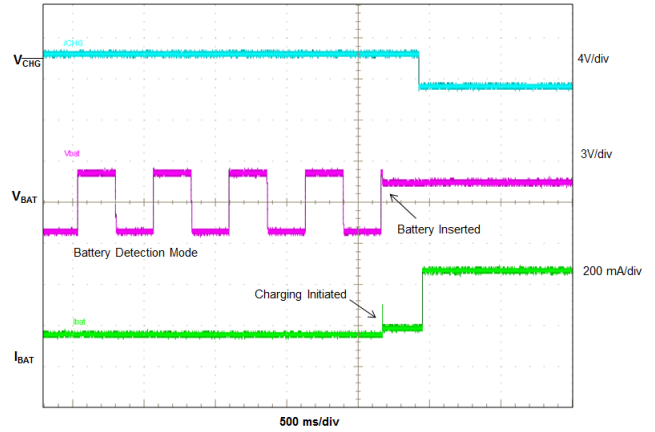

Figure 2. BATTERY DETECTION -- INSERTION

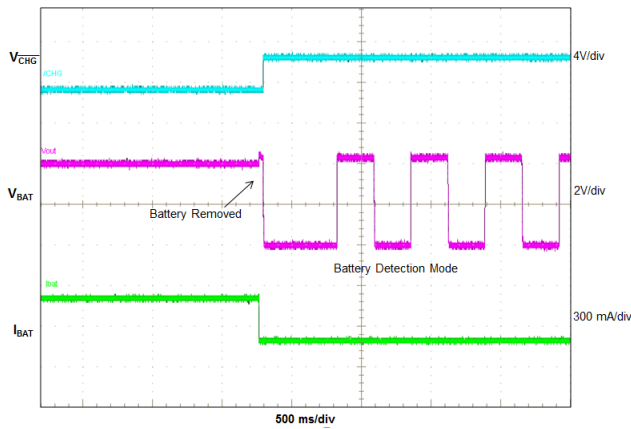

Figure 3. BATTERY DETECTION -- REMOVAL

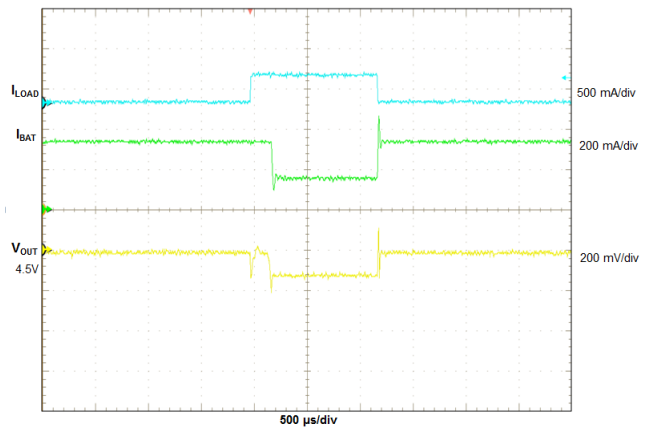

Figure 4. ENTERING AND EXITING DPPM MODE  
 $R_{LOAD} = 25\Omega$  to  $9\Omega$

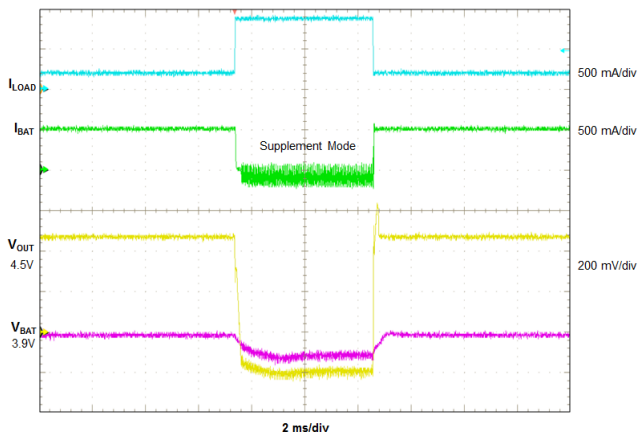

Figure 5. ENTERING AND EXITING BATTERY SUPPLEMENT  
MODE,  $R_{LOAD} = 25\Omega$  to  $4.5\Omega$

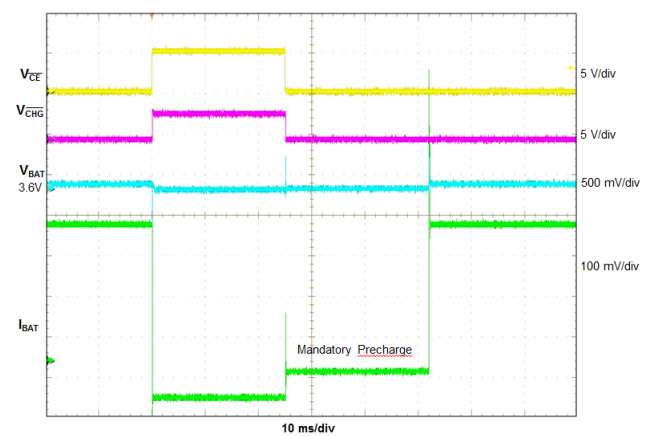
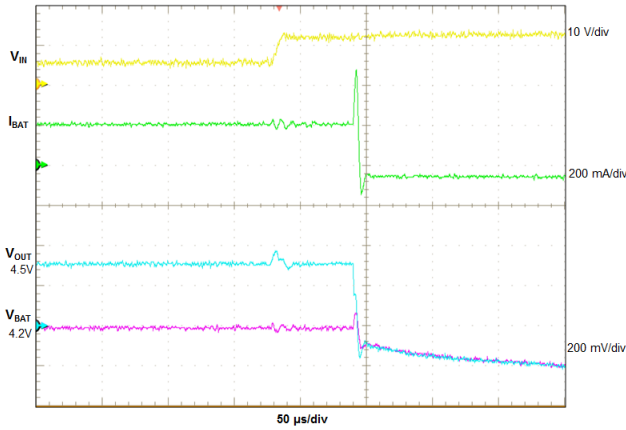

Figure 6. CHARGER ON/OFF USING  $\overline{CE}$

**TYPICAL CHARACTERISTICS (continued)**

Typical Application Circuit, EN1 = 0, EN2 = 1, T<sub>A</sub> = 25°C, unless otherwise noted.



**Figure 7. OVP FAULT, V<sub>IN</sub> = 6V to 15V  
R<sub>LOAD</sub> = 25Ω**

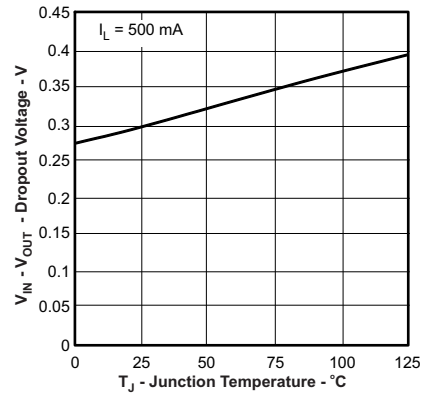

**Figure 8. DROPOUT VOLTAGE vs TEMPERATURE**

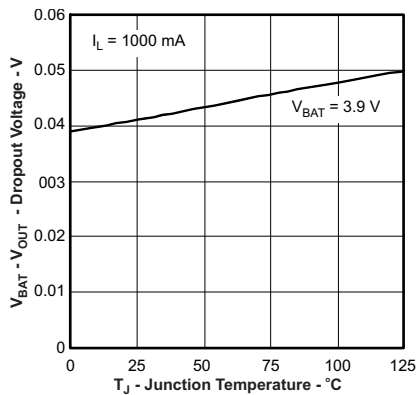

**Figure 9. DROPOUT VOLTAGE vs TEMPERATURE**

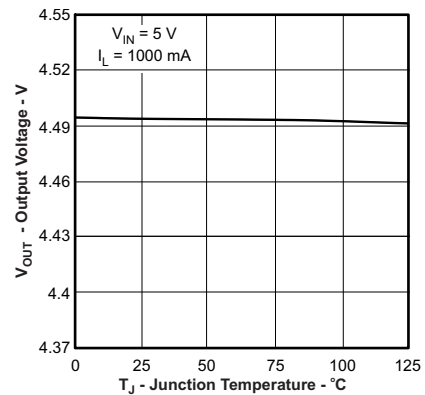

**Figure 10. OUTPUT VOLTAGE vs TEMPERATURE**

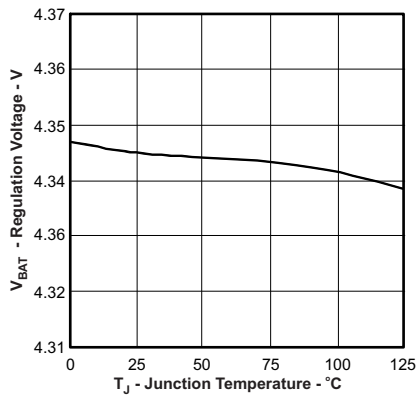

**Figure 11. OUTPUT REGULATION VOLTAGE vs TEMPERATURE**

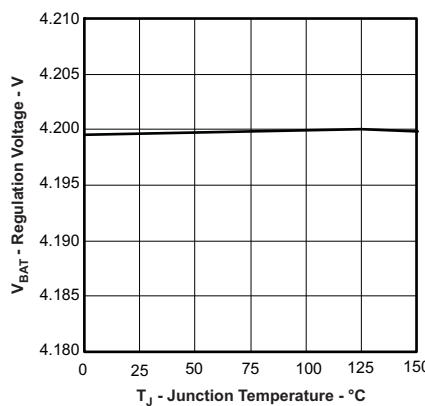

**Figure 12. BATTERY REGULATION VOLTAGE vs TEMPERATURE**

**TYPICAL CHARACTERISTICS (continued)**

Typical Application Circuit, EN1 = 0, EN2 = 1, T<sub>A</sub> = 25°C, unless otherwise noted.

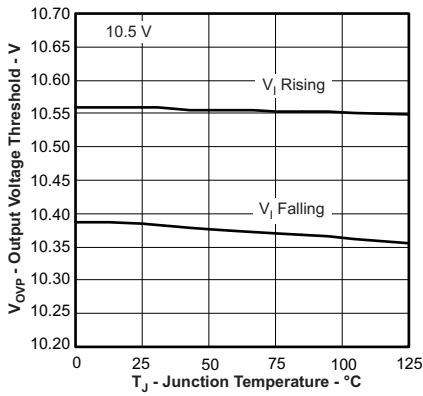

**Figure 13. OUTPUT VOLTAGE THRESHOLD vs TEMPERATURE (bq24230H)**

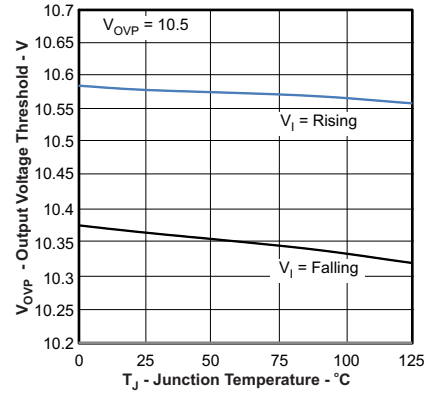

**Figure 14. OUTPUT VOLTAGE THRESHOLD vs TEMPERATURE (bq24232H)**

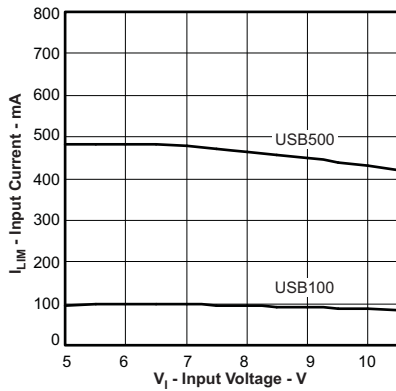

**Figure 15. INPUT CURRENT LIMIT THRESHOLD vs INPUT VOLTAGE**

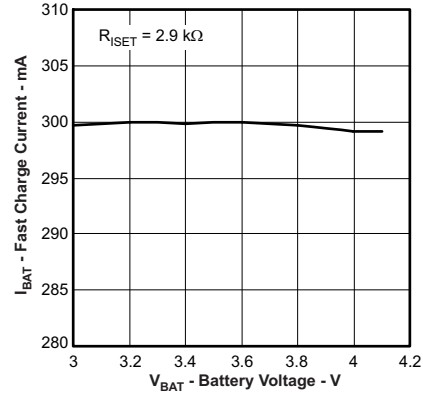

**Figure 16. FAST-CHARGE CURRENT vs BATTERY VOLTAGE**

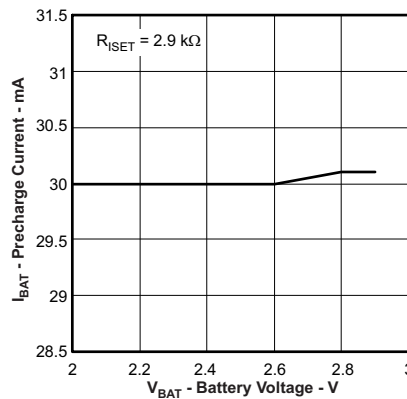

**Figure 17. PRECHARGE CURRENT vs BATTERY VOLTAGE**

## Detailed Description

### Overview

The bq2423xH devices are integrated Li-ion linear chargers and system power-path management devices targeted at space-limited portable applications. The device powers the system while simultaneously and independently charging the battery. This feature reduces the number of charge and discharge cycles on the battery, allows for proper charge termination, and enables the system to run with a defective or absent battery pack. It also allows instant system turnon even with a totally discharged battery. The input power source for charging the battery and running the system can be an AC adapter or a USB port. The devices feature dynamic power-path management (DPPM), which shares the source current between the system and battery charging and automatically reduces the charging current if the system load increases. When charging from a USB port, the input dynamic power management ( $V_{IN}$ -DPM) circuit reduces the input current limit if the input voltage falls below a threshold, preventing the USB port from crashing. The power-path architecture also permits the battery to supplement the system current requirements when the adapter cannot deliver the peak system currents.

Functional Block Diagram

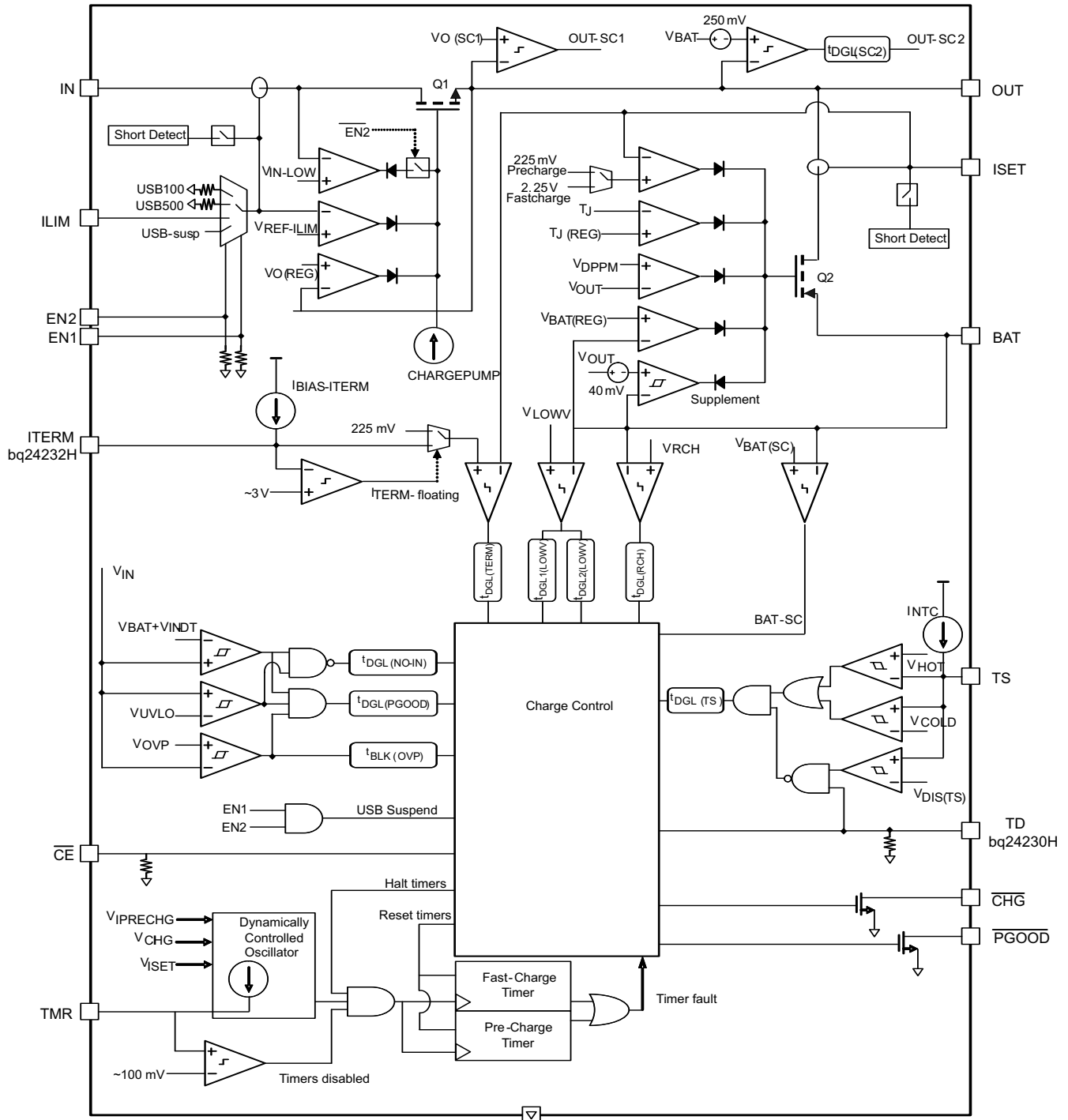

## Feature Description

### UNDERVOLTAGE LOCKOUT

The bq2423xH family remains in power-down mode when the input voltage at the IN pin is below the undervoltage lockout (UVLO) threshold.

During the power-down mode, the host commands at the control inputs ( $\overline{\text{CE}}$ , EN1 and EN2) are ignored. The Q1 FET connected between IN and OUT pins is off, and the status outputs  $\overline{\text{CHG}}$  and  $\overline{\text{PGOOD}}$  are high impedance. The Q2 FET that connects BAT to OUT is ON. During power-down mode, the  $V_{\text{OUT(SC2)}}$  circuitry is active and monitors for overload conditions on OUT.

### POWER ON

When  $V_{\text{IN}}$  exceeds the UVLO threshold, the bq2423xH powers up. While  $V_{\text{IN}}$  is below  $V_{\text{BAT}} + V_{\text{IN(DT)}}$ , the host commands at the control inputs ( $\overline{\text{CE}}$ , EN1, and EN2) are ignored. The Q1 FET connected between IN and OUT pins is off, and the status outputs  $\overline{\text{CHG}}$  and  $\overline{\text{PGOOD}}$  are high impedance. The Q2 FET that connects BAT to OUT is ON. During this mode, the  $V_{\text{OUT(SC2)}}$  circuitry is active and monitors for overload conditions on OUT.

When  $V_{\text{IN}}$  rises above  $V_{\text{BAT}} + V_{\text{IN(DT)}}$ ,  $\overline{\text{PGOOD}}$  is low to indicate that the valid power status and the  $\overline{\text{CE}}$ , EN1, and EN2 inputs are read. The device enters standby mode whenever (EN1, EN2) = (1, 1) or if an input overvoltage condition occurs. In standby mode, Q1 is OFF and Q2 is ON. (If SYSOFF is high, FET Q2 is off). During standby mode, the  $V_{\text{OUT(SC2)}}$  circuitry is active and monitors for overload conditions on OUT.

When the input voltage at IN is within the valid range:  $V_{\text{IN}} > \text{UVLO}$  **AND**  $V_{\text{IN}} > V_{\text{BAT}} + V_{\text{IN(DT)}}$  **AND**  $V_{\text{IN}} < V_{\text{OVP}}$ , and the EN1 and EN2 pins indicate that the USB suspend mode is not enabled [(EN1, EN2)  $\neq$  (HI, HI)], all internal timers and other circuit blocks are activated. The device checks for short circuits at the ISET and ILIM pins. If no short conditions exists, the device switches on the input FET Q1 with a 100-mA current limit to check for a short circuit at OUT. If  $V_{\text{OUT}}$  rises above  $V_{\text{SC}}$ , the FET Q1 switches to the current-limit threshold set by EN1, EN2, and  $R_{\text{ILIM}}$  and the device enters normal operation where the system is powered by the input source (Q1 is on), and the device continuously monitors the status of  $\overline{\text{CE}}$ , EN1, and EN2 as well as the input voltage conditions.

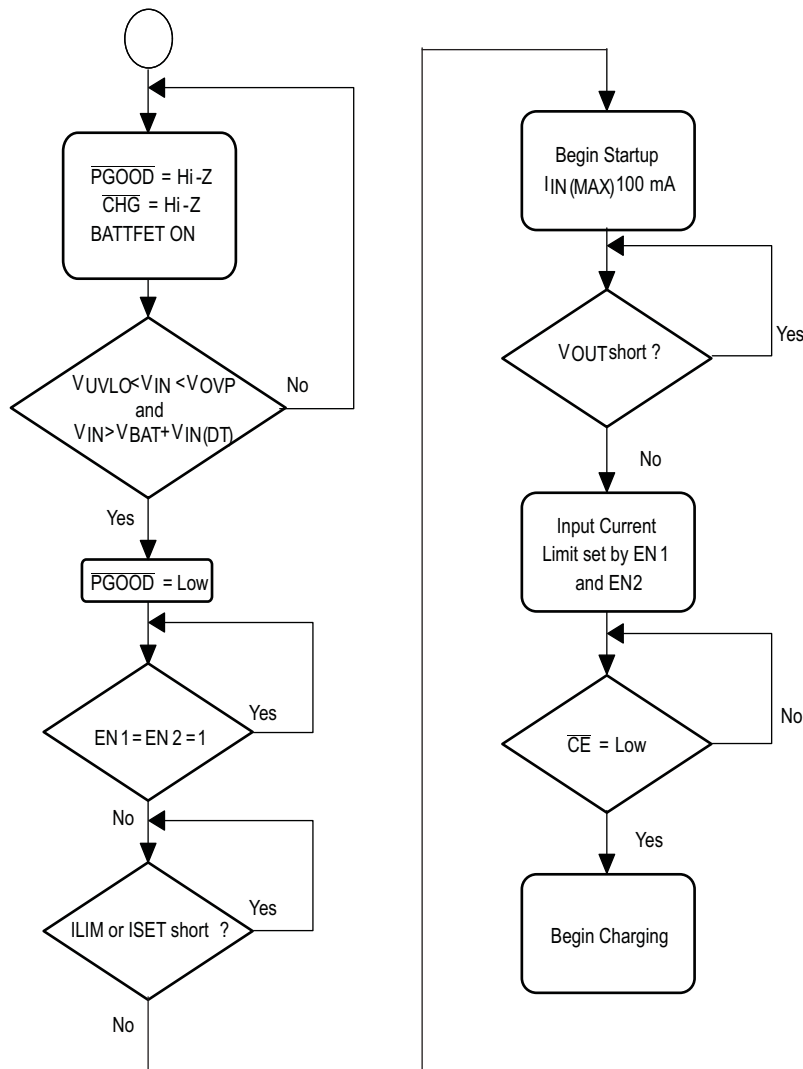

Figure 18. Start-up Flow Diagram

### POWER-PATH MANAGEMENT

The bq2423xH features an OUT output that powers the external load connected to the battery. This output is active whenever a source is connected to IN or BAT. The following sections discuss the behavior of OUT with a source connected to IN to charge the battery and a battery source only.

#### INPUT SOURCE CONNECTED – ADAPTER or USB

With a source connected, the power-path management circuitry of the bq2423xH monitors the input current continuously. The OUT output is regulated to a fixed voltage ( $V_{O(REG)}$ ). The current into IN is shared between charging the battery and powering the system load at OUT. The bq2423xH has internal selectable current limits of 100 mA (USB100) and 500 mA (USB500) for charging from USB ports, as well as a resistor-programmable input current limit.

The bq2423xH is USB-IF compliant for the inrush current testing. The USB spec allows up to 10 $\mu$ F to be hard-started, which establishes a 50  $\mu$ C as the maximum inrush charge value when exceeding 100 mA. The input current limit for the bq2423xH prevents the input current from exceeding this limit, even with system capacitances greater than 10  $\mu$ F. Note that the input capacitance to the device must be selected small enough to prevent a violation (<10  $\mu$ F), as this current is not limited. Figure 19 demonstrates the startup of the bq2423xH and compares it to the USB-IF specification.

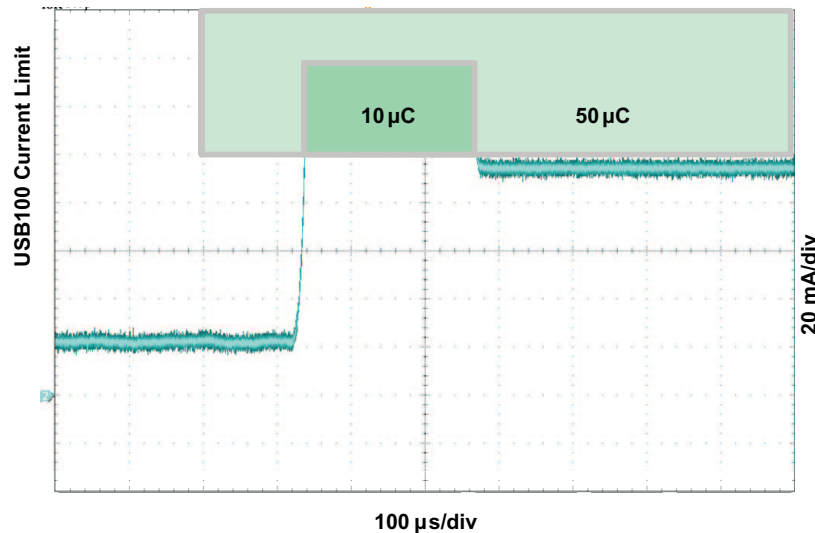

Figure 19. USB-IF Inrush Current Test

The input current limit selection is controlled by the state of the EN1 and EN2 pins as shown in Table 1. When using the resistor-programmable current limit, the input current limit is set by the value of the resistor connected from the ILIM pin to VSS and is given by the equation:

$$I_{IN-MAX} = K_{ILIM}/R_{ILIM}$$

The input current limit is adjustable up to 500 mA. The valid resistor range is 3.2 kΩ to 8 kΩ.

When the IN source is connected, priority is given to the system load. The DPPM and Battery Supplement modes are used to maintain the system load. Figure 20 illustrates examples of the DPPM and supplement modes. These modes are explained in detail in the following sections.

#### Input DPM Mode, $V_{IN-DPM}$

The bq2423xH uses the  $V_{IN-DPM}$  mode for operation from current-limited USB ports. When EN1 and EN2 are configured for USB100 (EN2=0, EN1=0) or USB500 (EN2=0, EN2=1) modes, the input voltage is monitored. If  $V_{IN}$  falls to  $V_{IN-DPM}$ , the input current limit is reduced to prevent the input voltage from falling further. This prevents the bq2423xH from crashing poorly designed or incorrectly configured USB sources.

#### DPPM Mode

When the sum of the charging and system load currents exceeds the preset maximum input current (programmed with EN1, EN2, and ILIM pins), the voltage at OUT decreases. Once the voltage on the OUT pin falls to  $V_{DPPM}$ , the bq2423xH enters DPPM mode. In this mode, the charging current is reduced as the OUT current goes up in order to maintain the system output. Battery termination is disabled while in DPPM mode.

#### Battery Supplement Mode

While in DPPM mode, if the charging current falls to zero and the system load current increases beyond the programmed input current limit, the voltage at OUT reduces further. When the OUT voltage drops below the battery voltage by  $V_{BSUP1}$ , the battery supplements the system load. The battery stops supplementing the system load when the voltage on the OUT pin rises above the battery voltage by  $V_{BSUP2}$ .

During supplement mode, the battery supplement current is not regulated; however, a short-circuit protection circuit is built in. If during battery supplement mode, the voltage at OUT drops 250 mV below the BAT voltage, the OUT output is turned off if the overload exists after  $t_{DGL(SC2)}$ . The short-circuit recovery timer then starts counting. After  $t_{REC(SC2)}$ , OUT turns on and attempts to restart. If the short circuit remains, OUT is turned off and the counter restarts. Battery termination is disabled while in supplement mode.

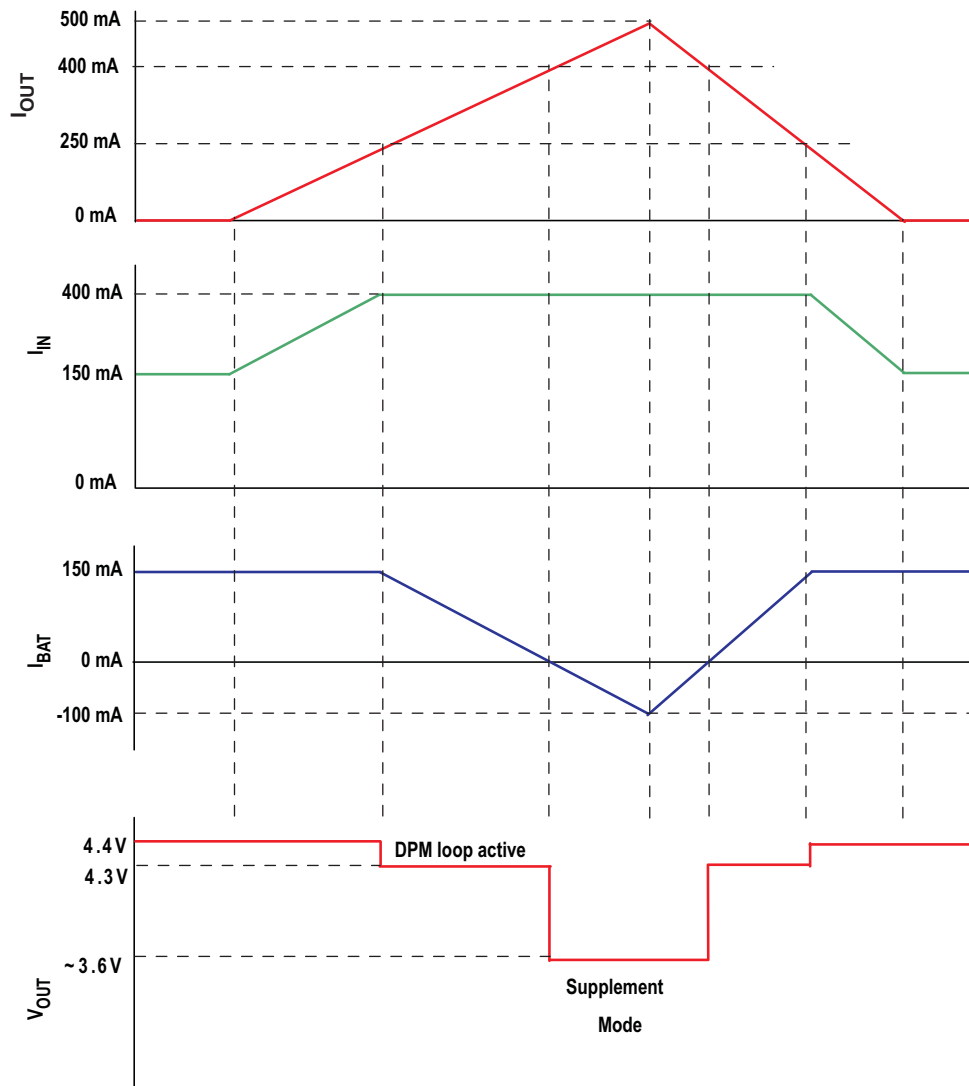

**Figure 20. bq2423xH DPM and Battery Supplement Modes**  
( $V_{OREG} = 4.4 \text{ V}$ ,  $V_{BAT} = 3.6 \text{ V}$ ,  $I_{LIM} = 400 \text{ mA}$ ,  $I_{CHG} = 150 \text{ mA}$ )

### INPUT SOURCE NOT CONNECTED

When no source is connected to the IN input, OUT is powered strictly from the battery. During this mode, the current into OUT is unregulated, similar to *Battery Supplement Mode*; however, the short-circuit circuitry is active. If the OUT voltage falls below the BAT voltage by 250 mV for longer than  $t_{DGL(SC2)}$ , OUT is turned off. The short-circuit recovery timer then starts counting. After  $t_{REC(SC2)}$ , OUT turns on and attempts to restart. If the short-circuit remains, OUT is turned off and the counter restarts. This ON/OFF cycle continues until the overload condition is removed.

### BATTERY CHARGING

Set  $\overline{CE}$  low to initiate battery charging. First, the device checks for a short circuit on the BAT pin by sourcing  $I_{BAT(SC)}$  to the battery and monitoring the voltage. When the BAT voltage exceeds  $V_{BAT(SC)}$ , the battery charging continues. The battery is charged in three phases: conditioning precharge, constant-current fast charge (current regulation), and a constant-voltage tapering (voltage regulation). In all charge phases, an internal control loop monitors the IC junction temperature and reduces the charge current if an internal temperature threshold is exceeded.

Figure 21 illustrates a normal Li-ion charge cycle using the bq2423xH:

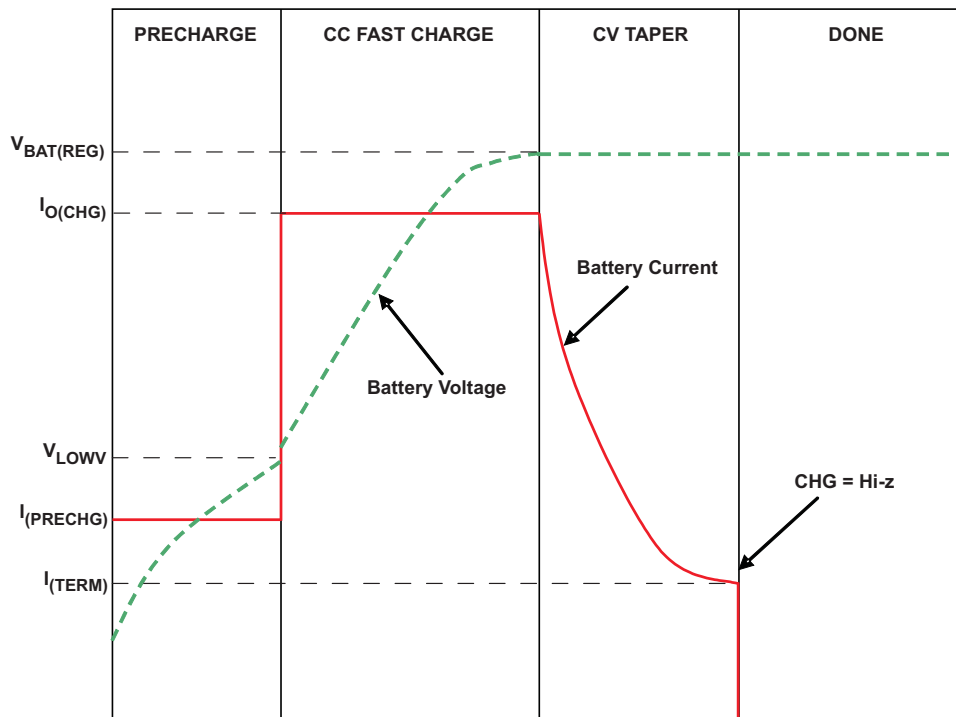

Figure 21.

In the precharge phase, the battery is charged with the precharge current ( $I_{PRECHG}$ ). Once the battery voltage crosses the  $V_{LOWV}$  threshold, the battery is charged with the fast-charge current ( $I_{CHG}$ ). As the battery voltage reaches  $V_{BAT(REG)}$ , the battery is held at a constant voltage of  $V_{BAT(REG)}$  and the charge current tapers off as the battery approaches full charge. When the battery current reaches  $I_{TERM}$ , the CHG pin indicates *charging done* by going high impedance.

$$I_{PRECHG} = K_{PRECHG}/R_{ISET} \quad (1)$$

Termination detection is disabled whenever the charge rate is reduced because of the actions of the thermal loop, the DPPM loop, or the  $V_{IN(LOW)}$  loop.

The value of the fast-charge current is set by the resistor connected from the ISET pin to VSS, and is given by Equation 2:

$$I_{CHG} = K_{ISET}/R_{ISET} \quad (2)$$

The charge current limit is adjustable from 25 mA to 500 mA. The valid resistor range is 1.74 kΩ to 34.8 kΩ. Note that if  $I_{CHG}$  is programmed as greater than the input current limit, the battery does not charge at the rate of  $I_{CHG}$ , but at the slower rate of  $I_{IN(MAX)}$  (minus the load current on the OUT pin, if any). In this case, the charger timers are proportionately slowed down.

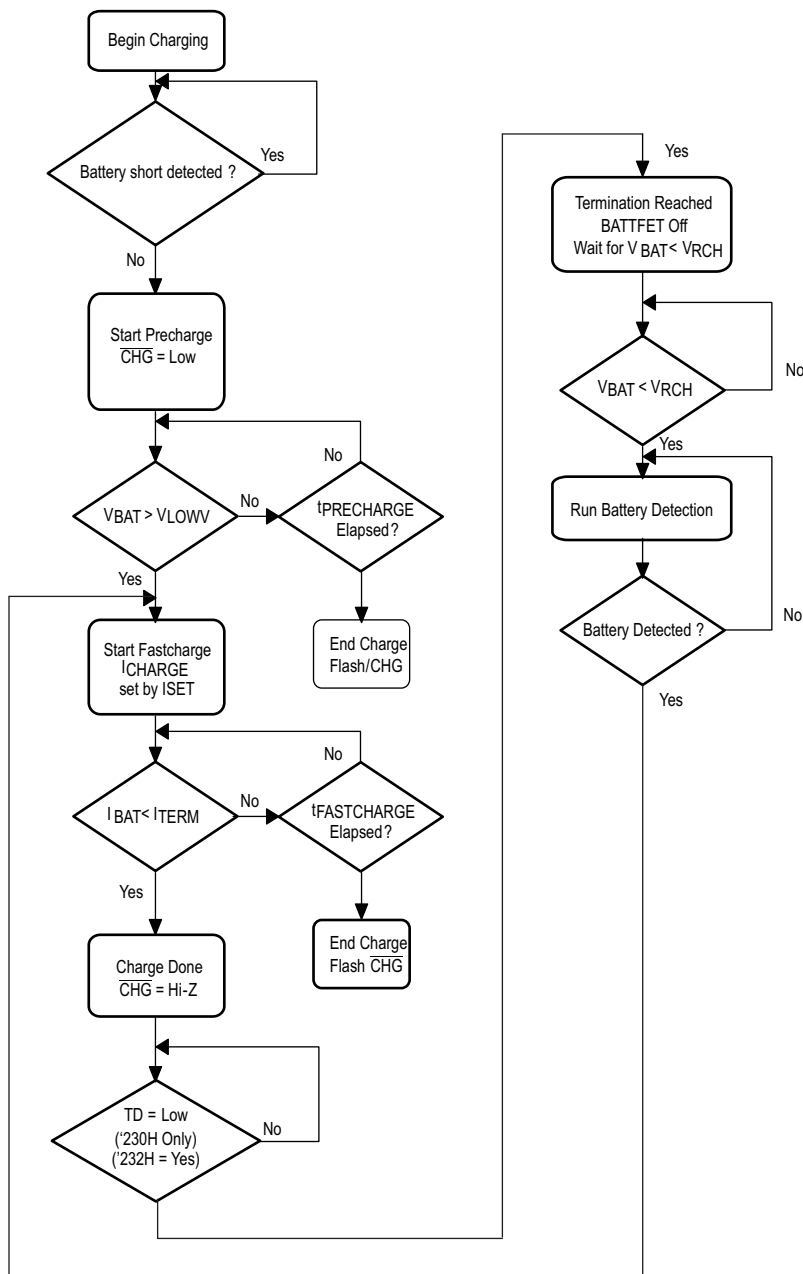

Figure 22. Battery Charging Flow Diagram

**CHARGE CURRENT TRANSLATOR**

When the charger is enabled, internal circuits generate a current proportional to the charge current at the ISET input. The current out of ISET is 1/400 (±10%) of the charge current. This current, when applied to the external charge current programming resistor, R<sub>ISET</sub>, generates an analog voltage that can be monitored by an external host to calculate the current sourced from BAT.

$$V_{ISET} = (I_{CHARGE} / 400) \times R_{ISET} \tag{3}$$

## BATTERY DETECTION AND RECHARGE

The bq2423xH automatically detects if a battery is connected or removed. Once a charge cycle is complete, the battery voltage is monitored. When the battery voltage falls below  $V_{RCH}$ , the battery detection routine is run. The detection routine first applies  $I_{BAT(DET)}$  for  $t_{DET}$  to see if  $V_{BAT}$  drops below  $V_{LOWV}$ . If not, it indicates that the battery is still connected, but has discharged. If  $\overline{CE}$  is low, the charger is turned on again to top off the battery. During this recharge cycle, the  $\overline{CHG}$  output remains high-impedance as recharge cycles are not indicated by the  $\overline{CHG}$  pin. If the BAT voltage falls below  $V_{LOWV}$  during the battery detection test, it indicates that the battery has been removed or the protector is open. Next, the precharge current is applied for  $t_{DET}$  to close the protector if possible. If the battery voltage does not rise above  $V_{RCH}$ , it indicates that the protector is closed, or a battery has been inserted, and a new charge cycle begins. If the voltage rises above  $V_{RCH}$ , the battery is determined missing and the detection routine continues. The battery detection runs until a battery is detected.

### TERMINATION DISABLE (TD Input, bq24230H)

The bq24230H contains a TD input that allows termination to be enabled/disabled. Connect TD to a logic high to disable charge termination. When termination is disabled, the device goes through the precharge, fast-charge, and CV phases, then remains in the CV phase. During the CV phase, the charger maintains the output voltage at BAT equal to  $V_{BAT(REG)}$ , and charging current does not terminate. BAT sources currents up to  $I_{CHG}$  or  $I_{IN-MAX}$ , whichever is less. Battery detection is not performed. The  $\overline{CHG}$  output is high impedance once the current falls below  $I_{TERM}$  and does not go low until the input power or  $\overline{CE}$  are toggled. When termination is disabled, the precharge and fast-charge safety timers are also disabled. Battery pack temperature sensing (TS pin functionality) is also disabled if the TD pin is high and the TS pin is unconnected.

### ADJUSTABLE TERMINATION THRESHOLD (ITERM Input, bq24232H)

The termination current threshold for the bq24232H is user-programmable. Set the termination current by connecting a resistor from ITERM to VSS. For USB100, mode (EN1 = EN2 = VSS), the termination current value is calculated as:

$$I_{TERM} = 0.01 \times R_{ITERM} / R_{ISET}$$

In the other input current limit modes (EN1  $\neq$  EN2), the termination current value is calculated as:

$$I_{TERM} = 0.03 \times R_{ITERM} / R_{ISET}$$

The termination current is programmable up to 50% of the fast-charge current. The  $R_{ITERM}$  resistor must be less than 15 k $\Omega$ . Leave ITERM unconnected to select the default internally set termination current.

### DYNAMIC CHARGE TIMERS (TMR Input)

The bq2423xH devices contain internal safety timers for the precharge and fast-charge phases to prevent potential damage to the battery and the system. The timers begin at the start of the respective charge cycles. The timer values are programmed by connecting a resistor from TMR to VSS. The resistor value is calculated using the following equation:

$$t_{PRECHG} = K_{TMR} \times R_{TMR}$$

$$t_{MAXCHG} = 10 \times K_{TMR} \times R_{TMR}$$

Leave TMR unconnected to select the internal default timers. Disable the timers by connecting TMR to VSS. Reset the timers by toggling the CE pin, or by toggling EN1, EN2 pin to put the device in and out of USB suspend mode (EN1 = HI, EN2 = HI).

Timers are suspended when the device is in thermal shutdown, and the timers are slowed proportionally to the charge current when the device enters thermal regulation. For the bq24230H, the timers are disabled when TD is connected to a high logic level.

During the fast-charge phase, several events increase the timer durations.

1. The system load current activates the DPPM loop which reduces the available charging current
2. The input current is reduced because the input voltage has fallen to  $V_{IN(LOW)}$
3. The device has entered thermal regulation because the IC junction temperature has exceeded  $T_{J(REG)}$

During each of these events, the internal timers are slowed down proportionately to the reduction in charging current. For example, if the charging current is reduced by half for two minutes, the timer clock is reduced to half the frequency and the counter counts half as fast resulting in only one minute of counted time.

## STATUS INDICATORS ( $\overline{\text{PGOOD}}$ , $\overline{\text{CHG}}$ )

The bq2423xH contains two open-drain outputs that signal its status. The  $\overline{\text{PGOOD}}$  output signals when a valid input source is connected.  $\overline{\text{PGOOD}}$  is low when  $(V_{\text{BAT}} + V_{\text{IN(DT)}}) < V_{\text{IN}} < V_{\text{OVP}}$ . When the input voltage is outside of this range,  $\overline{\text{PGOOD}}$  is high impedance.

The  $\overline{\text{CHG}}$  output signals when a new charge cycle is initiated. After a charge cycle is initiated,  $\overline{\text{CHG}}$  goes low once the battery is above the short-circuit threshold.  $\overline{\text{CHG}}$  goes high impedance once the charge current falls below  $I_{\text{TERM}}$ .  $\overline{\text{CHG}}$  remains high impedance until the input power is removed and reconnected or the  $\overline{\text{CE}}$  pin is toggled. It does not signal subsequent recharge cycles.

**Table 2.  $\overline{\text{PGOOD}}$  STATUS INDICATOR**

Input State	$\overline{\text{PGOOD}}$ Output
$V_{\text{IN}} < V_{\text{UVLO}}$	Hi impedance
$V_{\text{UVLO}} < V_{\text{IN}} < V_{\text{IN(DT)}} + V_{\text{BAT}}$	Hi impedance
$V_{\text{IN(DT)}} + V_{\text{BAT}} < V_{\text{IN}} < V_{\text{OVP}}$	Low
$V_{\text{IN}} > V_{\text{OVP}}$	Hi impedance

**Table 3.  $\overline{\text{CHG}}$  STATUS INDICATOR**

Charge State	$\overline{\text{CHG}}$ Output
Charging	Low (first charge cycle)
Charging terminated	Hi impedance until power or $\overline{\text{CE}}$ is toggled
Recharging after termination	Hi impedance
Charging suspended by thermal loop	Low (first charge cycle)
Safety timers expired	Flashing at 2Hz
IC disabled or no valid input power	Hi impedance

### TIMER FAULT

If the precharge timer expires before the battery voltage reaches  $V_{\text{LOWV}}$ , the bq2423xH indicates a fault condition. Additionally, if the battery current does not fall to  $I_{\text{TERM}}$  before the fast-charge timer expires, a fault is indicated. The  $\overline{\text{CHG}}$  output flashes at approximately 2 Hz to indicate a fault condition.

### THERMAL REGULATION AND THERMAL SHUTDOWN

The bq2423xH contain a thermal regulation loop that monitors the die temperature. If the die temperature exceeds  $T_{\text{J(REG)}}$ , the device automatically reduces the charging current to prevent the die temperature from increasing further. In some cases, the die temperature continues to rise despite the operation of the thermal loop, particularly under high  $V_{\text{IN}}$  and heavy  $\text{OUT}$  system load conditions. Under these conditions, if the die temperature increases to  $T_{\text{J(OFF)}}$ , the input FET Q1 is turned OFF. FET Q2 is turned ON to ensure that the battery still powers the load on  $\text{OUT}$ . Once the device die temperature cools by  $T_{\text{J(OFF-HYS)}}$ , the input FET Q1 is turned on and the device returns to thermal regulation. Continuous overtemperature conditions result in a hiccup mode. Safety timers are slowed proportionally to the charge current in thermal regulation. Battery termination is disabled during thermal regulation and thermal shutdown.

Note that this feature monitors the die temperature of the bq2423xH. This is not synonymous with ambient temperature. Self-heating exists due to the power dissipated in the IC because of the linear nature of the battery charging algorithm and the LDO mode for  $\text{OUT}$ .

A modified charge cycle with the thermal loop active is shown in [Figure 23](#):

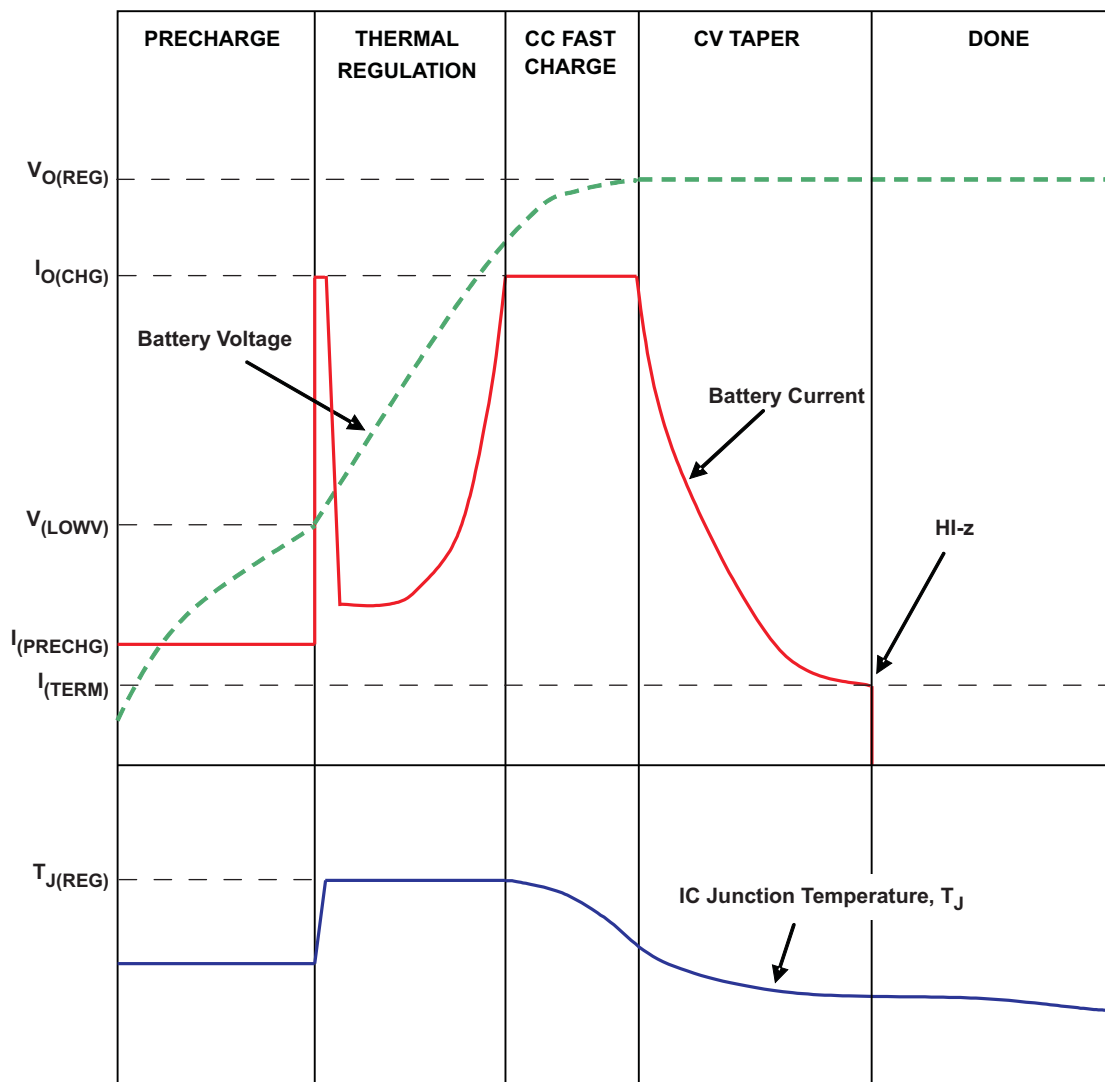

Figure 23.

## BATTERY PACK TEMPERATURE MONITORING

The bq2423xH features an external battery pack temperature monitoring input. The TS input connects to the NTC resistor in the battery pack to monitor battery temperature and prevent dangerous overtemperature conditions.

During charging,  $I_{NTC}$  is sourced to TS and the voltage at TS is continuously monitored. If, at any time, the voltage at TS is outside of the operating range ( $V_{COLD}$  to  $V_{HOT}$ ), charging is suspended. The timers maintain their values but suspend counting. When the voltage measured at TS returns to within the operation window, charging is resumed and the timers continue counting. When charging is suspended due to a battery pack temperature fault, the  $\overline{CHG}$  pin remains low and continues to indicate *charging*.

For the bq24230H, battery pack temperature sensing is disabled when termination is disabled ( $TD = High$ ) and the voltage at TS is greater than  $V_{DIS(TS)}$ . The battery pack temperature monitoring is disabled in all devices by connecting a 10-k $\Omega$  resistor from TS to VSS.

The allowed temperature range for a 103AT-2 type thermistor is 0°C to 50°C. However, the user can increase the range by adding two external resistors. See Figure 24 for the circuit. The values for Rs and Rp are calculated using the following equations:

$$R_s = \frac{-(R_{TH} + R_{TC}) \pm \sqrt{\left( (R_{TH} + R_{TC})^2 - 4 \left\{ R_{TH} \times R_{TC} + \frac{V_H \times V_C}{(V_H - V_C) \times I_{TS}} \times (R_{TC} - R_{TH}) \right\} \right)}}{2} \quad (4)$$

$$R_p = \frac{V_H \times (R_{TH} + R_s)}{I_{TS} \times (R_{TH} + R_s) - V_H} \quad (5)$$

Where:

- R<sub>TH</sub>: Thermistor Hot Trip Value found in thermistor data sheet
- R<sub>TC</sub>: Thermistor Cold Trip Value found in thermistor data sheet
- V<sub>H</sub>: IC's Hot Trip Threshold = 0.3V nominal
- V<sub>C</sub>: IC's Cold Trip Threshold = 2.1V nominal
- I<sub>TS</sub>: IC's Output Current Bias = 75µA nominal
- NTC Thermistor Semitec 103AT-4

Rs and Rp 1% values were chosen closest to calculated values

Cold Temp Resistance and Trip Threshold; Ω (°C)	Hot Temp Resistance and Trip Threshold; Ω (°C)	External Bias Resistor, Rs (Ω)	External Bias Resistor, Rp (Ω)
28000 (-0.6)	4000 (51)	0	∞
28480 (-1)	3536 (55)	487	845000
28480 (-1)	3021 (60)	1000	549000
33890 (-5)	4026 (51)	76.8	158000
33890 (-5)	3536 (55)	576	150000
33890 (-5)	3021 (60)	1100	140000

R<sub>HOT</sub> and R<sub>COLD</sub> are the thermistor resistance at the desired hot and cold temperatures, respectively. Note that the temperature window cannot be tightened more than using on the thermistor connected to TS, it can only be extended.

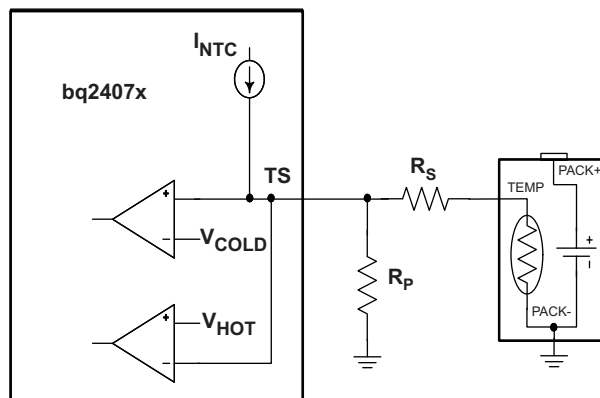

Figure 24. Extended TS Temperature Thresholds

## APPLICATION AND IMPLEMENTATION

### APPLICATION CIRCUITS

$V_{IN} = V_{UVLO}$  to  $V_{OVP}$ ,  $I_{FASTCHG} = 200$  mA,  $I_{IN(MAX)} = 500$  mA, Battery Temperature Charge Range  $0^{\circ}\text{C}$  to  $50^{\circ}\text{C}$ , 6.25-hour Fast Charge Safety Timer.

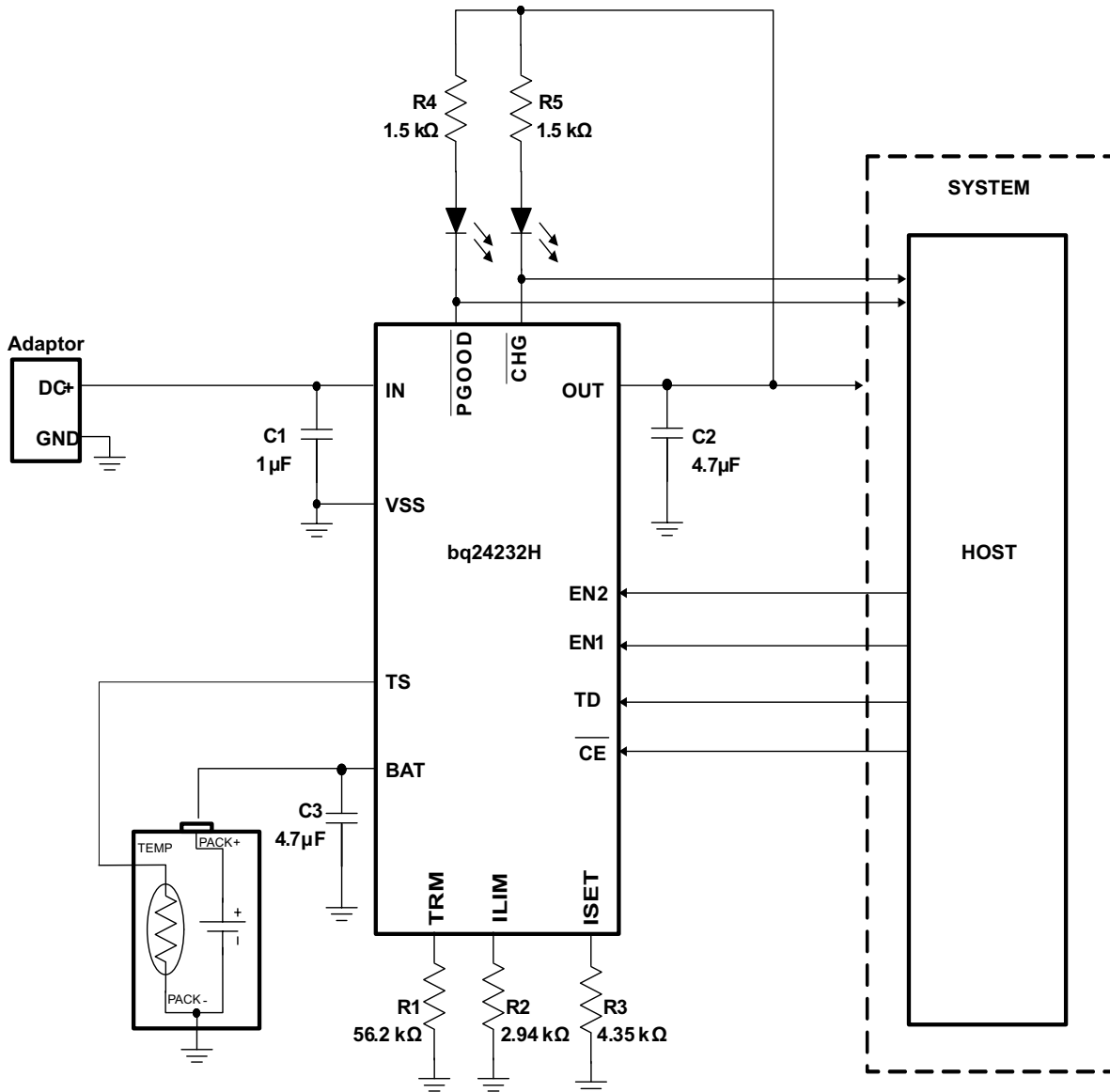

Figure 25. Using the bq24230H in a Host Controlled Charger Application

$V_{IN} = V_{UVLO}$  to  $V_{OVP}$ ,  $I_{FASTCHG} = 200$  mA,  $I_{IN(MAX)} = 500$  mA, 25-mA Termination Current, ISET mode (EN1=0, EN2=1), Battery Temperature Charge Range 0°C to 50°C, 6.25-hour Fast Charge Safety Timer.

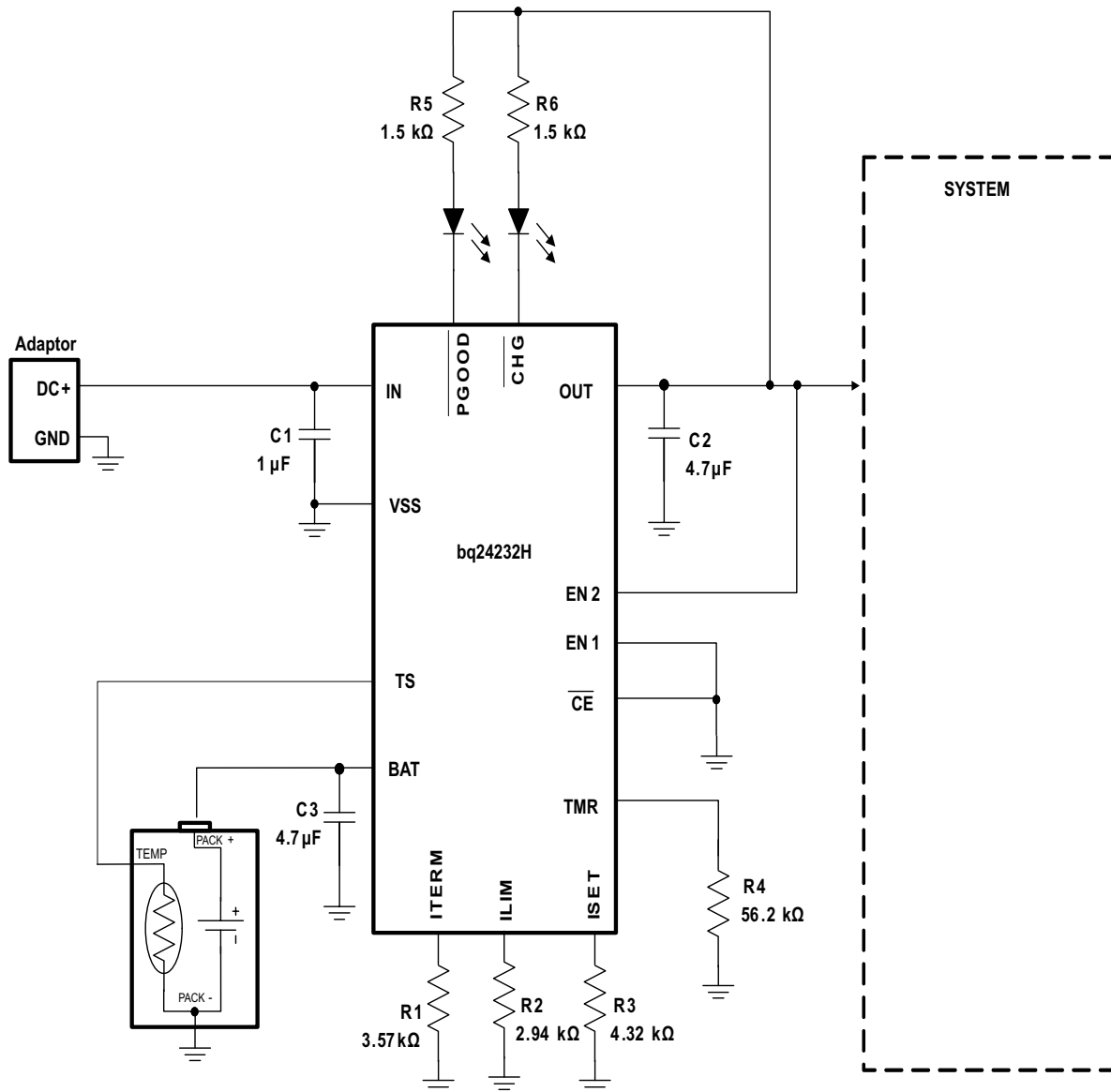

Figure 26. Using the bq24232H in a Stand-Alone Charger Application

## EXPLANATION OF DEGLITCH TIMES AND COMPARATOR HYSTERESIS

Figures not to scale

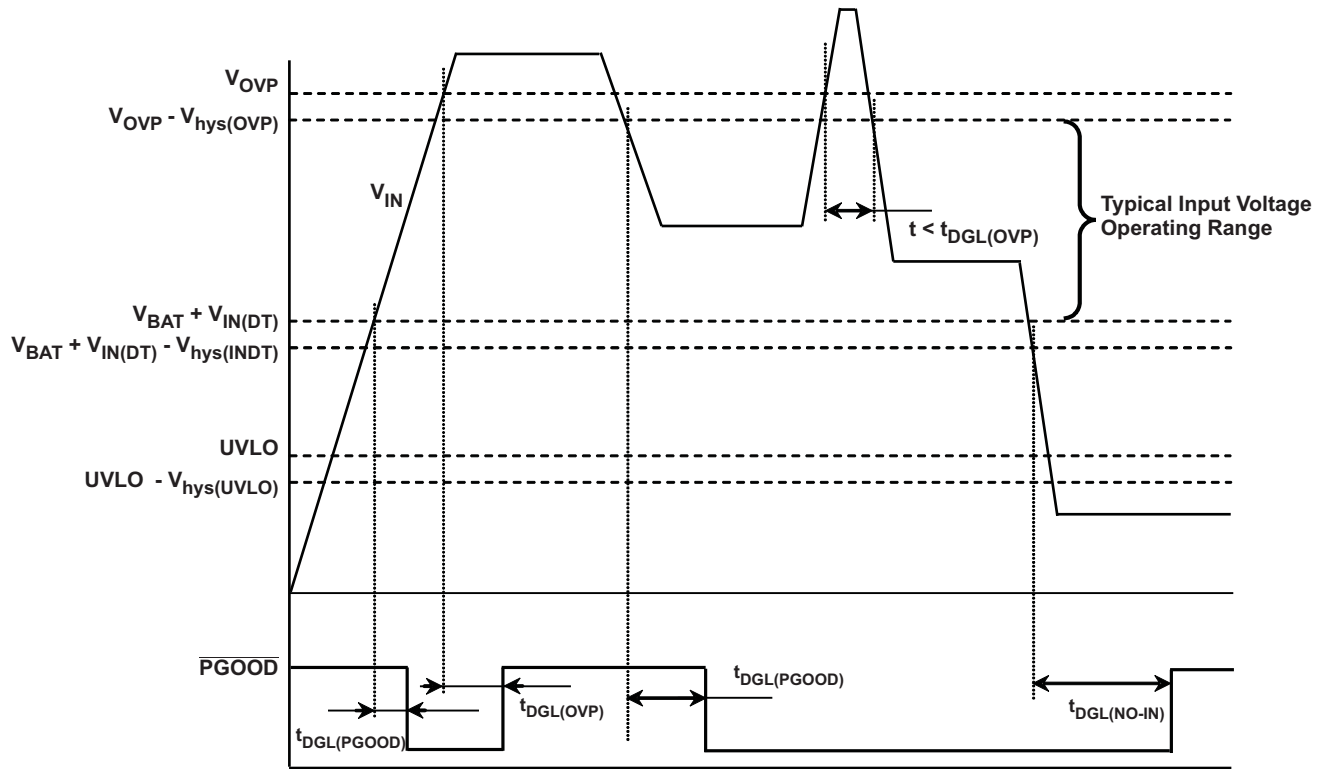

Figure 27. Power Up, Power Down

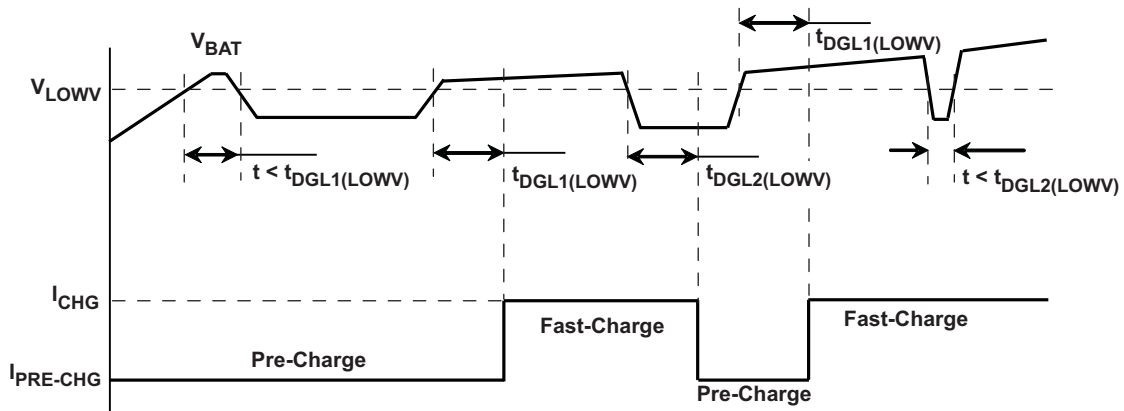

Figure 28. Pre- to Fast-Charge, Fast- to Precharge Transition –  $t_{DGL1(LOWV)}$ ,  $t_{DGL2(LOWV)}$

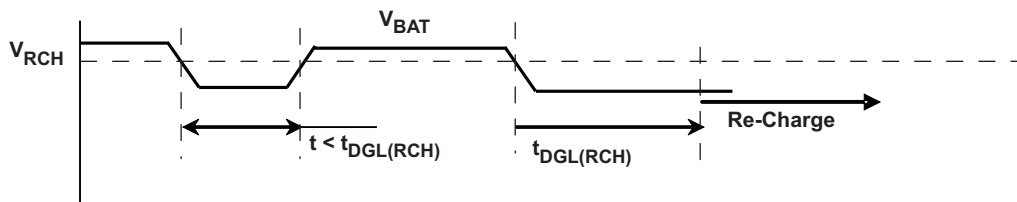

Figure 29. Recharge –  $t_{DGL(RCH)}$

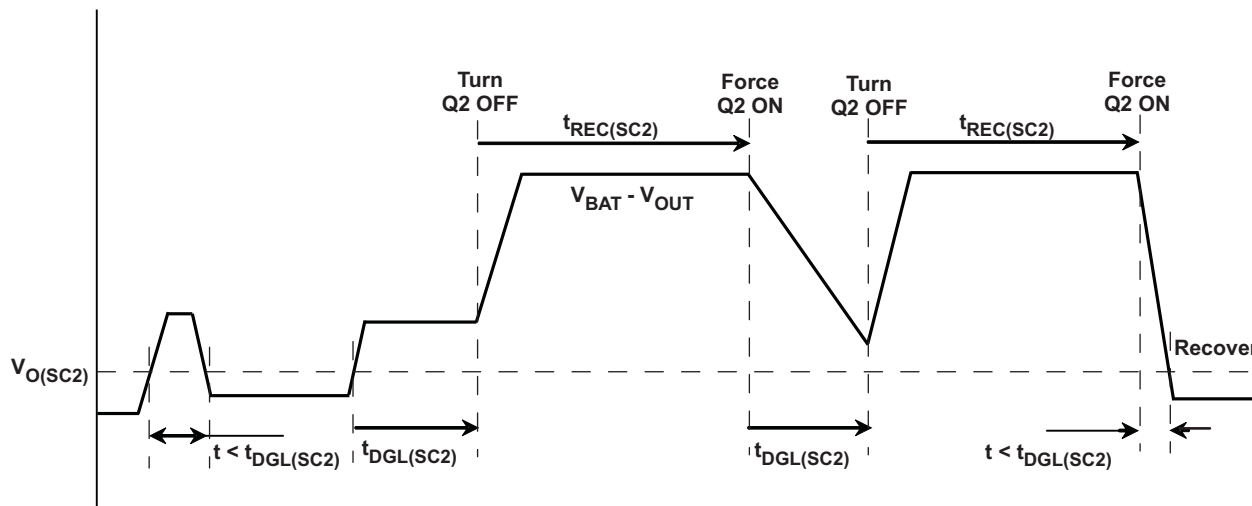

Figure 30. OUT Short-Circuit – Supplement Mode

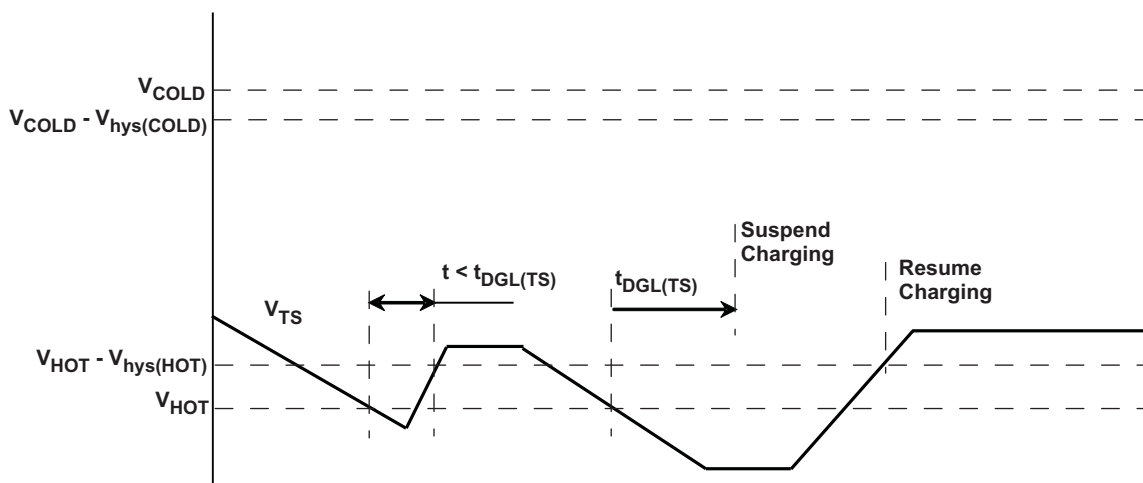

Figure 31. Battery Pack Temperature Sensing – TS Pin. Battery Temperature Increasing

## bq24232H CHARGER DESIGN EXAMPLE

See [Figure 25](#) for the Design Example Schematic.

### Requirements

- Supply voltage = 5 V
- Fast-charge current of approximately 200 mA; ISET - pin 16
- Input Current Limit = 500 mA; ILIM - pin 12
- Termination Current = 25 mA - pin 15
- Safety timer duration, Fast charge = 6.25 hours; TMR – pin 14
- TS – Battery Temperature Sense = 10 kΩ NTC (103AT-2)

### Calculations

**Program the Fast-Charge Current (ISET):**

$$R_{ISET} = K_{ISET} / I_{CHG}$$

$K_{ISET} = 870 \text{ A}\Omega$  from the electrical characteristics table.

$$R_{ISET} = 870 \text{ A}\Omega / 0.2 \text{ A} = 4.35 \text{ k}\Omega$$

Select the closest standard value, which for this case is 4.32 k $\Omega$ . Connect this resistor between ISET (pin 16) and  $V_{SS}$ .

#### **Program the Input Current Limit (ILIM)**

$$R_{ILIM} = K_{ILIM} / I_{L\_MAX}$$

$K_{ILIM} = 1530 \text{ A}\Omega$  from the electrical characteristics table.

$$R_{ISET} = 1530 \text{ A}\Omega / 0.5 \text{ A} = 3.06 \text{ k}\Omega$$

Select the closest standard value, which for this case is 3.06 k $\Omega$ . Connect this resistor between ILIM (pin 12) and  $V_{SS}$ .

#### **Program the Termination Current Threshold (ITERM)**

$$R_{ITERM} = R_{ISET} \times I_{TERM} / K_{ITERM}$$

$K_{ITERM} = 0.03 \text{ A}$  from electrical characteristics table

$$R_{ITERM} = 4.32 \text{ k}\Omega \times 0.025 \text{ A} / 0.03 \text{ A} = 3.6 \text{ k}\Omega$$

Select the closest standard value, which for this case is 3.57 k $\Omega$ . Connect this resistor between ITERM (pin 15) and  $V_{SS}$ .

#### **Program 6.25-Hour Fast-Charge Safety Timer (TMR)**

$$R_{TMR} = t_{MAXCHG} / (10 \times K_{TMR})$$

$K_{TMR} = 40 \text{ s/k}\Omega$  from the electrical characteristics table.

$$R_{TMR} = (6.25 \text{ hr} \times 3600 \text{ s/hr}) / (10 \times 40 \text{ s/k}\Omega) = 56.25 \text{ k}\Omega$$

Select the closest standard value, which for this case is 56.2 k $\Omega$ . Connect this resistor between TMR (pin 2) and  $V_{SS}$ .

#### **TS Function**

Use a 10-k $\Omega$  NTC thermistor in the battery pack (103AT). To disable the temperature sense function, use a fixed 10-k $\Omega$  resistor between the TS (pin 1) and  $V_{SS}$ . Pay close attention to the linearity of the chosen NTC so that it provides the desired hot and cold turnoff thresholds.

#### **CHG and PGOOD**

LED Status: connect a 1.5-k $\Omega$  resistor in series with a LED between OUT and  $\overline{\text{CHG}}$  and OUT and  $\overline{\text{PGOOD}}$ .

Processor Monitoring Status: connect a pullup resistor (approximately 100 k $\Omega$ ) between the processor's power rail and CHG and PGOOD.

#### **SELECTING IN, OUT, AND BAT PIN CAPACITORS**

In most applications, all that is needed is a high-frequency decoupling capacitor (ceramic) on the power pin, input, output, and battery pins. Using the values shown on the application diagram is recommended. After evaluation of these voltage signals with real system operational conditions, the user can determine if capacitance values can be adjusted toward the minimum recommended values (dc load application) or higher values for fast, high-amplitude, pulsed load applications.

---

#### **NOTE**

If designed with high input voltage sources (bad adapters or wrong adapters), the capacitor needs to be rated appropriately. Ceramic capacitors are tested to 2x their rated values so a 16-V capacitor may be adequate for a 30-V transient (verify tested rating with capacitor manufacturer).

---

## THERMAL PACKAGE

The bq2423xH is packaged in a thermally enhanced MLP package. The package includes a thermal pad to provide an effective thermal contact between the IC and the printed-circuit board (PCB). The power pad must be directly connected to the V<sub>SS</sub> pin. Full PCB design guidelines for this package are provided in the application report entitled: QFN/SON PCB Attachment ([SLUA271](#)). The most common measure of package thermal performance is thermal impedance ( $\theta_{JA}$ ) measured (or modeled) from the chip junction to the air surrounding the package surface (ambient). The mathematical expression for  $\theta_{JA}$  is:

$$\theta_{JA} = (T_J - T) / P$$

Where:

$T_J$  = chip junction temperature

$T$  = ambient temperature

$P$  = device power dissipation

Factors that can greatly influence the measurement and calculation of  $\theta_{JA}$  include:

1. Whether the device is board mounted
2. Trace size, composition, thickness, and geometry
3. Orientation of the device (horizontal or vertical)
4. Volume of the ambient air surrounding the device under test and airflow
5. Whether other surfaces are in close proximity to the device being tested

Due to the charge profile of Li-ion batteries, the maximum power dissipation is typically seen at the beginning of the charge cycle when the battery voltage is at its lowest. Typically, after fast charge begins, the pack voltage increases to ~3.4 V within the first 2 minutes. The thermal time constant of the assembly typically takes a few minutes to heat up so when doing maximum power dissipation calculations, 3.4 V is a good minimum voltage to use. This is easy to verify, with the system and a fully discharged battery, by plotting temperature on the bottom of the PCB under the IC (pad must have multiple vias), the charge current and the battery voltage as a function of time. The fast-charge current starts to taper off if the part goes into thermal regulation.

The device power dissipation,  $P$ , is a function of the charge rate and the voltage drop across the internal PowerFET. It can be calculated from the following equation when a battery pack is being charged :

$$P = [V_{(IN)} - V_{(OUT)}] \times I_{(OUT)} + [V_{(OUT)} - V_{(BAT)}] \times I_{(BAT)}$$

The thermal loop feature reduces the charge current to limit excessive IC junction temperature. It is recommended that the design not run in thermal regulation for typical operating conditions (nominal input voltage and nominal ambient temperatures) and use the feature for nontypical situations such as hot environments or higher than normal input source voltage. With that said, the IC still performs as described, if the thermal loop is always active.

## Half-Wave Adapters

Some low-cost adapters implement a half rectifier topology, which causes the adapter output voltage to fall below the battery voltage during part of the cycle. To enable operation with low-cost adapters under those conditions, the bq2423xH family keeps the charger on for at least 20 ms (typical) after the input power puts the part in sleep mode. This feature enables use of external low-cost adapters using 50-Hz networks.

## Sleep Mode

After entering sleep mode for >20 ms, the internal FET connection between the IN and OUT pin is disabled and pulling the input to ground does not discharge the battery, other than the leakage on the BAT pin. If the user has a full 1000-mAhr battery and the leakage is 10  $\mu$ A, then it takes 1000 mAhr/10  $\mu$ A = 100000 hours (11.4 years) to discharge the battery. The battery's self-discharge is typically 5 times higher.

## Layout

### Layout Guidelines

- To obtain optimal performance, the decoupling capacitor from IN to GND (thermal pad) and the output filter capacitors from OUT to GND (thermal pad) must be placed as close as possible to the bq2423xH, with short trace runs to both IN, OUT, and GND (thermal pad).
- All low-current GND connections must be kept separate from the high-current charge or discharge paths from the battery. Use a single-point ground technique incorporating both the small signal ground path and the power ground path.
- The high current charge paths into the IN pin and from the OUT pin must be sized appropriately for the maximum charge current in order to avoid voltage drops in these traces.
- The bq2423xH family is packaged in a thermally enhanced MLP package. The package includes a thermal pad to provide an effective thermal contact between the IC and the printed-circuit board (PCB); this thermal pad is also the main ground connection for the device. Connect the thermal pad to the PCB ground connection. Full PCB design guidelines for this package are provided in the application report entitled: QFN/SON PCB Attachment ([SLUA271](#)).

**PACKAGING INFORMATION**

Orderable Device	Status (1)	Package Type	Package Drawing	Pins	Package Qty	Eco Plan (2)	Lead/Ball Finish (6)	MSL Peak Temp (3)	Op Temp (°C)	Device Marking (4/5)	Samples
BQ24232HRGTR	PREVIEW	QFN	RGT	16	3000	Green (RoHS & no Sb/Br)	CU NIPDAU	Level-2-260C-1 YEAR	-40 to 85	24232H	
BQ24232HRGTT	PREVIEW	QFN	RGT	16	250	Green (RoHS & no Sb/Br)	CU NIPDAU	Level-2-260C-1 YEAR	-40 to 85	24232H	

(1) The marketing status values are defined as follows:

**ACTIVE:** Product device recommended for new designs.

**LIFEBUY:** TI has announced that the device will be discontinued, and a lifetime-buy period is in effect.

**NRND:** Not recommended for new designs. Device is in production to support existing customers, but TI does not recommend using this part in a new design.

**PREVIEW:** Device has been announced but is not in production. Samples may or may not be available.

**OBsolete:** TI has discontinued the production of the device.

(2) Eco Plan - The planned eco-friendly classification: Pb-Free (RoHS), Pb-Free (RoHS Exempt), or Green (RoHS & no Sb/Br) - please check <http://www.ti.com/productcontent> for the latest availability information and additional product content details.

**TBD:** The Pb-Free/Green conversion plan has not been defined.

**Pb-Free (RoHS):** TI's terms "Lead-Free" or "Pb-Free" mean semiconductor products that are compatible with the current RoHS requirements for all 6 substances, including the requirement that lead not exceed 0.1% by weight in homogeneous materials. Where designed to be soldered at high temperatures, TI Pb-Free products are suitable for use in specified lead-free processes.

**Pb-Free (RoHS Exempt):** This component has a RoHS exemption for either 1) lead-based flip-chip solder bumps used between the die and package, or 2) lead-based die adhesive used between the die and leadframe. The component is otherwise considered Pb-Free (RoHS compatible) as defined above.

**Green (RoHS & no Sb/Br):** TI defines "Green" to mean Pb-Free (RoHS compatible), and free of Bromine (Br) and Antimony (Sb) based flame retardants (Br or Sb do not exceed 0.1% by weight in homogeneous material)

(3) MSL, Peak Temp. - The Moisture Sensitivity Level rating according to the JEDEC industry standard classifications, and peak solder temperature.

(4) There may be additional marking, which relates to the logo, the lot trace code information, or the environmental category on the device.

(5) Multiple Device Markings will be inside parentheses. Only one Device Marking contained in parentheses and separated by a "~" will appear on a device. If a line is indented then it is a continuation of the previous line and the two combined represent the entire Device Marking for that device.

(6) Lead/Ball Finish - Orderable Devices may have multiple material finish options. Finish options are separated by a vertical ruled line. Lead/Ball Finish values may wrap to two lines if the finish value exceeds the maximum column width.

**Important Information and Disclaimer:** The information provided on this page represents TI's knowledge and belief as of the date that it is provided. TI bases its knowledge and belief on information provided by third parties, and makes no representation or warranty as to the accuracy of such information. Efforts are underway to better integrate information from third parties. TI has taken and continues to take reasonable steps to provide representative and accurate information but may not have conducted destructive testing or chemical analysis on incoming materials and chemicals. TI and TI suppliers consider certain information to be proprietary, and thus CAS numbers and other limited information may not be available for release.

In no event shall TI's liability arising out of such information exceed the total purchase price of the TI part(s) at issue in this document sold by TI to Customer on an annual basis.

RGT (S-PVQFN-N16)

PLASTIC QUAD FLATPACK NO-LEAD

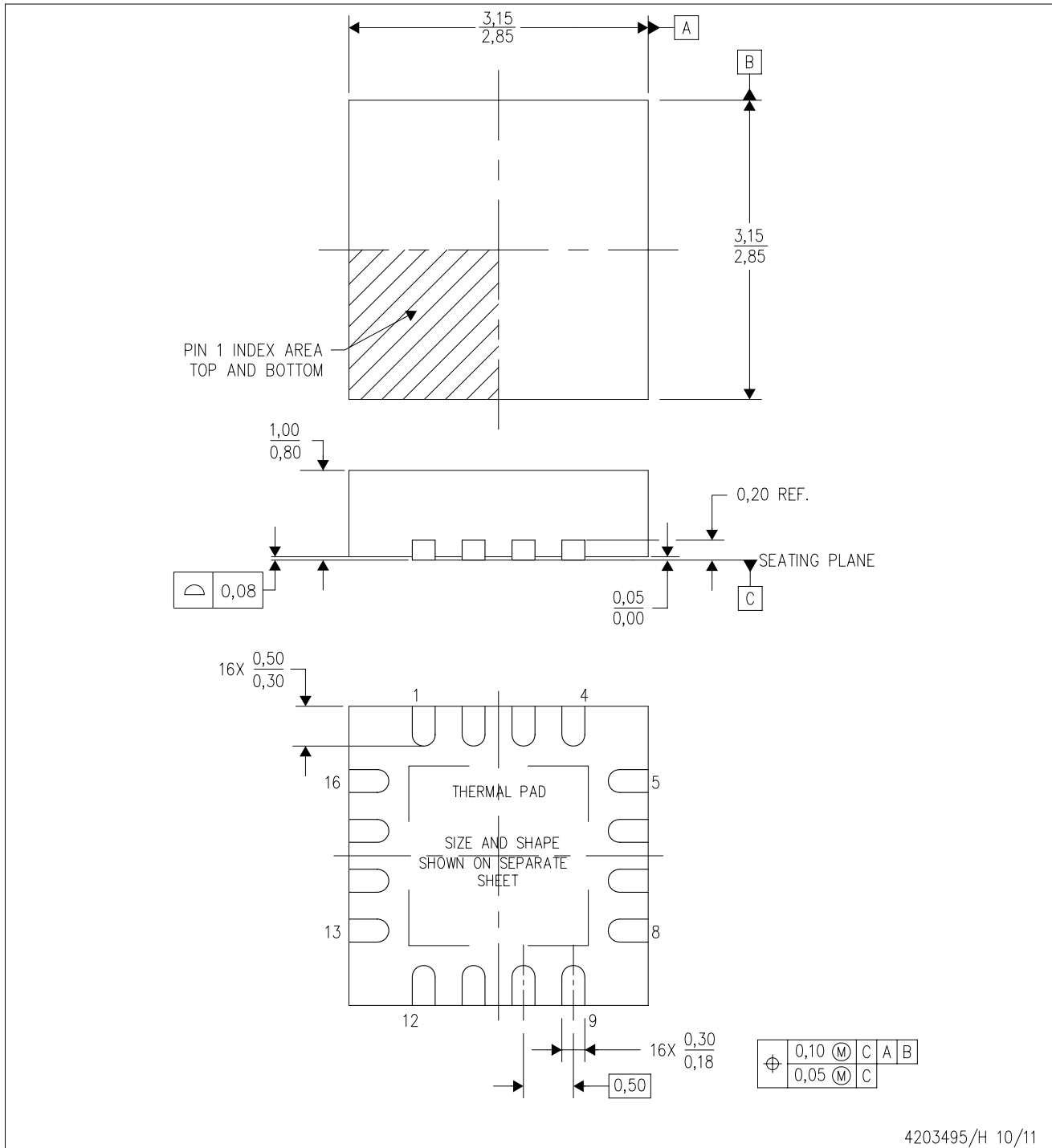

- NOTES:
- All linear dimensions are in millimeters. Dimensioning and tolerancing per ASME Y14.5M-1994.
  - This drawing is subject to change without notice.
  - Quad Flatpack, No-leads (QFN) package configuration.
  - The package thermal pad must be soldered to the board for thermal and mechanical performance.
  - See the additional figure in the Product Data Sheet for details regarding the exposed thermal pad features and dimensions.
  - Falls within JEDEC MO-220.

# THERMAL PAD MECHANICAL DATA

RGT (S-PVQFN-N16)

PLASTIC QUAD FLATPACK NO-LEAD

## THERMAL INFORMATION

This package incorporates an exposed thermal pad that is designed to be attached directly to an external heatsink. The thermal pad must be soldered directly to the printed circuit board (PCB). After soldering, the PCB can be used as a heatsink. In addition, through the use of thermal vias, the thermal pad can be attached directly to the appropriate copper plane shown in the electrical schematic for the device, or alternatively, can be attached to a special heatsink structure designed into the PCB. This design optimizes the heat transfer from the integrated circuit (IC).

For information on the Quad Flatpack No-Lead (QFN) package and its advantages, refer to Application Report, QFN/SON PCB Attachment, Texas Instruments Literature No. SLUA271. This document is available at [www.ti.com](http://www.ti.com).

The exposed thermal pad dimensions for this package are shown in the following illustration.

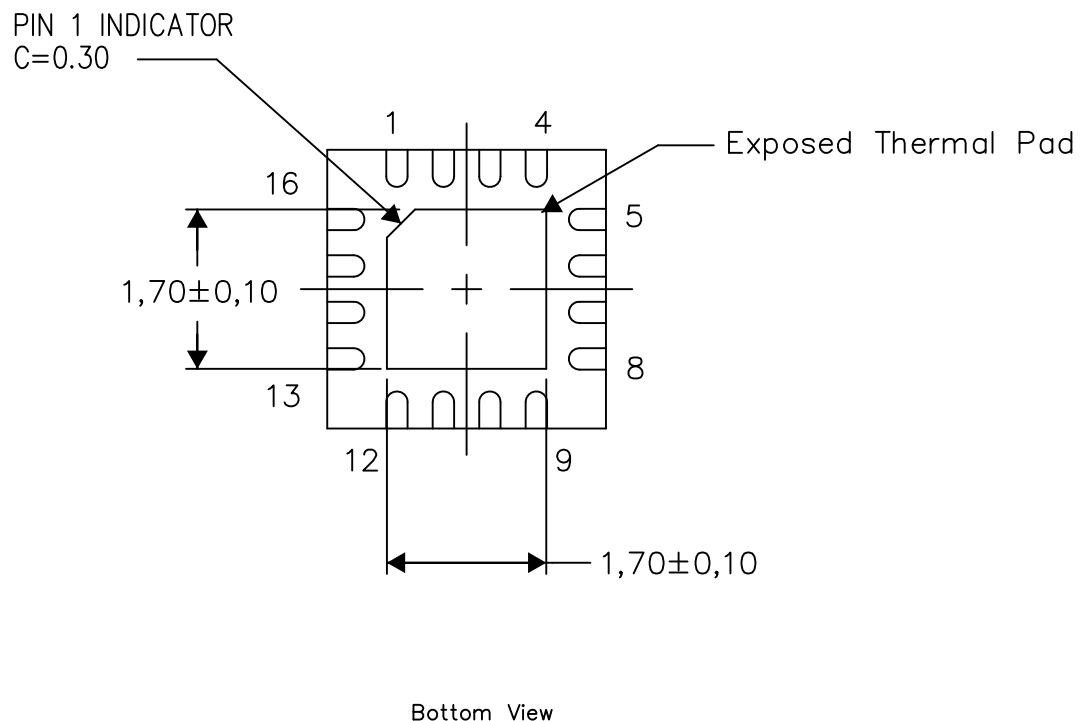

Exposed Thermal Pad Dimensions

4206349-4/U 09/13

NOTE: All linear dimensions are in millimeters

RGT (S-PVQFN-N16)

PLASTIC QUAD FLATPACK NO-LEAD

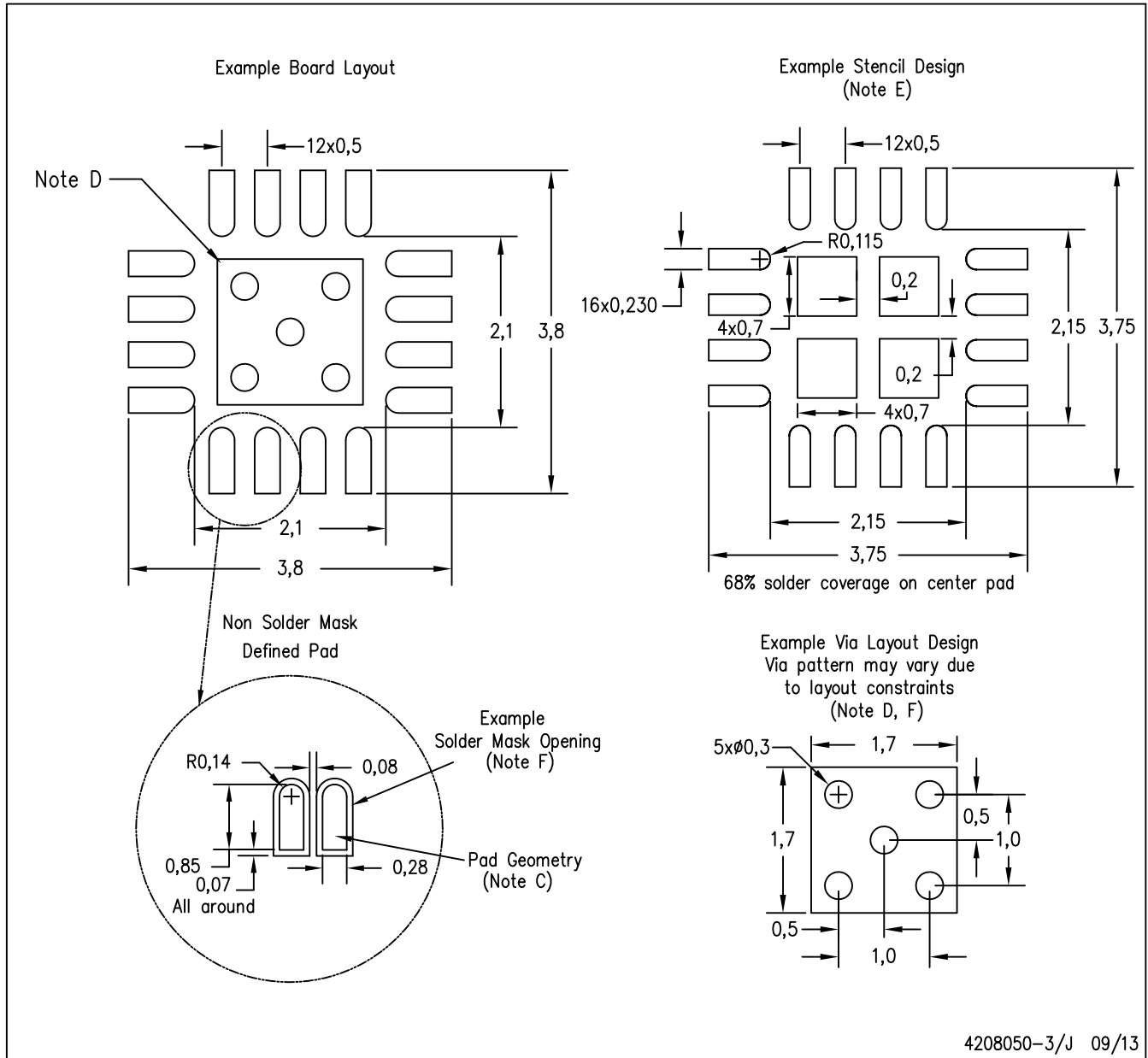

- NOTES:
- A. All linear dimensions are in millimeters.
  - B. This drawing is subject to change without notice.
  - C. Publication IPC-7351 is recommended for alternate designs.
  - D. This package is designed to be soldered to a thermal pad on the board. Refer to Application Note, QFN/SON PCB Attachment, Texas Instruments Literature No. SLUA271, and also the Product Data Sheets for specific thermal information, via requirements, and recommended board layout. These documents are available at [www.ti.com](http://www.ti.com) <<http://www.ti.com>>.
  - E. Laser cutting apertures with trapezoidal walls and also rounding corners will offer better paste release. Customers should contact their board assembly site for stencil design recommendations. Refer to IPC 7525 for stencil design considerations.
  - F. Customers should contact their board fabrication site for minimum solder mask web tolerances between signal pads.

## IMPORTANT NOTICE

Texas Instruments Incorporated and its subsidiaries (TI) reserve the right to make corrections, enhancements, improvements and other changes to its semiconductor products and services per JESD46, latest issue, and to discontinue any product or service per JESD48, latest issue. Buyers should obtain the latest relevant information before placing orders and should verify that such information is current and complete. All semiconductor products (also referred to herein as "components") are sold subject to TI's terms and conditions of sale supplied at the time of order acknowledgment.

TI warrants performance of its components to the specifications applicable at the time of sale, in accordance with the warranty in TI's terms and conditions of sale of semiconductor products. Testing and other quality control techniques are used to the extent TI deems necessary to support this warranty. Except where mandated by applicable law, testing of all parameters of each component is not necessarily performed.

TI assumes no liability for applications assistance or the design of Buyers' products. Buyers are responsible for their products and applications using TI components. To minimize the risks associated with Buyers' products and applications, Buyers should provide adequate design and operating safeguards.

TI does not warrant or represent that any license, either express or implied, is granted under any patent right, copyright, mask work right, or other intellectual property right relating to any combination, machine, or process in which TI components or services are used. Information published by TI regarding third-party products or services does not constitute a license to use such products or services or a warranty or endorsement thereof. Use of such information may require a license from a third party under the patents or other intellectual property of the third party, or a license from TI under the patents or other intellectual property of TI.

Reproduction of significant portions of TI information in TI data books or data sheets is permissible only if reproduction is without alteration and is accompanied by all associated warranties, conditions, limitations, and notices. TI is not responsible or liable for such altered documentation. Information of third parties may be subject to additional restrictions.

Resale of TI components or services with statements different from or beyond the parameters stated by TI for that component or service voids all express and any implied warranties for the associated TI component or service and is an unfair and deceptive business practice. TI is not responsible or liable for any such statements.

Buyer acknowledges and agrees that it is solely responsible for compliance with all legal, regulatory and safety-related requirements concerning its products, and any use of TI components in its applications, notwithstanding any applications-related information or support that may be provided by TI. Buyer represents and agrees that it has all the necessary expertise to create and implement safeguards which anticipate dangerous consequences of failures, monitor failures and their consequences, lessen the likelihood of failures that might cause harm and take appropriate remedial actions. Buyer will fully indemnify TI and its representatives against any damages arising out of the use of any TI components in safety-critical applications.

In some cases, TI components may be promoted specifically to facilitate safety-related applications. With such components, TI's goal is to help enable customers to design and create their own end-product solutions that meet applicable functional safety standards and requirements. Nonetheless, such components are subject to these terms.

No TI components are authorized for use in FDA Class III (or similar life-critical medical equipment) unless authorized officers of the parties have executed a special agreement specifically governing such use.

Only those TI components which TI has specifically designated as military grade or "enhanced plastic" are designed and intended for use in military/aerospace applications or environments. Buyer acknowledges and agrees that any military or aerospace use of TI components which have **not** been so designated is solely at the Buyer's risk, and that Buyer is solely responsible for compliance with all legal and regulatory requirements in connection with such use.

TI has specifically designated certain components as meeting ISO/TS16949 requirements, mainly for automotive use. In any case of use of non-designated products, TI will not be responsible for any failure to meet ISO/TS16949.

### Products

Audio	<a href="http://www.ti.com/audio">www.ti.com/audio</a>
Amplifiers	<a href="http://amplifier.ti.com">amplifier.ti.com</a>
Data Converters	<a href="http://dataconverter.ti.com">dataconverter.ti.com</a>
DLP® Products	<a href="http://www.dlp.com">www.dlp.com</a>
DSP	<a href="http://dsp.ti.com">dsp.ti.com</a>
Clocks and Timers	<a href="http://www.ti.com/clocks">www.ti.com/clocks</a>
Interface	<a href="http://interface.ti.com">interface.ti.com</a>
Logic	<a href="http://logic.ti.com">logic.ti.com</a>
Power Mgmt	<a href="http://power.ti.com">power.ti.com</a>
Microcontrollers	<a href="http://microcontroller.ti.com">microcontroller.ti.com</a>
RFID	<a href="http://www.ti-rfid.com">www.ti-rfid.com</a>
OMAP Applications Processors	<a href="http://www.ti.com/omap">www.ti.com/omap</a>
Wireless Connectivity	<a href="http://www.ti.com/wirelessconnectivity">www.ti.com/wirelessconnectivity</a>

### Applications

Automotive and Transportation	<a href="http://www.ti.com/automotive">www.ti.com/automotive</a>
Communications and Telecom	<a href="http://www.ti.com/communications">www.ti.com/communications</a>
Computers and Peripherals	<a href="http://www.ti.com/computers">www.ti.com/computers</a>
Consumer Electronics	<a href="http://www.ti.com/consumer-apps">www.ti.com/consumer-apps</a>
Energy and Lighting	<a href="http://www.ti.com/energy">www.ti.com/energy</a>
Industrial	<a href="http://www.ti.com/industrial">www.ti.com/industrial</a>
Medical	<a href="http://www.ti.com/medical">www.ti.com/medical</a>
Security	<a href="http://www.ti.com/security">www.ti.com/security</a>
Space, Avionics and Defense	<a href="http://www.ti.com/space-avionics-defense">www.ti.com/space-avionics-defense</a>
Video and Imaging	<a href="http://www.ti.com/video">www.ti.com/video</a>

### TI E2E Community

[e2e.ti.com](http://e2e.ti.com)